

AIRLESSCO AIRLESS LINE STRIPERS SERVICE/OPERATION MANUAL



SURE STRIPE 4500

&

SURE STRIPE 6000



Manufactured by: AIRLESSCO BY DUROTECH CO.

P.O. Box 8006, Moorpark, CA 93020-8006, Ship to: 5397 Commerce Ave.,
Moorpark, CA 93021 Tel: 805-523-0211 Fax: 805-523-1063

TABLE OF CONTENTS

Introduction

Sure Stripe 4500/6000 Specifications . . .	1
Safety Warnings	2

Getting Started

Flushing	6
How to Flush	7
Setting Up	8
Starting Up	9
Daily Maintenance	10
Pressure Relief Procedure	11

Repairs/Maintenance Instructions

Line Striping Operation	12
Airlessco 007X & XL Gun Repairs	14
Spray Gun Operation	15
Line Striping Tip Chart	16
Oil & Lubrication Procedure	17
Troubleshooting	17
Servicing Fluid Pump	18
Servicing Upper/Lower Check Valves . .	19
V-Packing Replacement	20
Troubleshooting	
Clutch Does Not Engage	22
Replacement of Electrical Control Board	23
Pressure Calibration for	
Electrical Control Board	23
Clutch Replacement	24

Product Diagrams & Parts Lists

Airlessco Gun Components	13
Fluid Pump	21
Clutch Assembly	25
Engine Assembly	25
Manifold Filter	26
Suction Assembly	26
Sure Stripe 6000 Parts List	27
First Gun Assembly	28
Second Gun Assembly	28
Sure Stripe Brake Assembly	29
Gun Holder Assembly	29
Lock Assembly	30
Swivel Wheel - Sure Stripe 6000	30
Swivel Wheel - Sure Stripe 4500	31
Power Unit Assembly	32
Sure Stripe 4500 Parts List	33
Paint System Assembly	34



INTRODUCTION

AIRLESSCO SURE STRIPE 4500 & SURE STRIPE 6000

These gas powered, piston driven, airless linestripers have been designed to have the reliability and versatility to meet the tough demands of the professional line striping contractor.

SPECIFICATIONS



**SURE
STRIPE
4500**



SURE STRIPE 4500
Pressure: 0-3000 psi
Output: 1.3 gpm
Tip Size: 1 gun up to 0.035
2 guns up to 0.023
Engine: 5.5 hp Honda



**SURE
STRIPE
6000**



SURE STRIPE 6000
Pressure: 0 - 3000 psi
Output: 1.5 gpm
Tip Size: 1 gun up to 0.039
2 guns up to 0.028
Engine: 5.5 hp Honda

IMPORTANT WARNING !!

HANDLE THIS UNIT AS YOU WOULD A LOADED FIREARM!!

High pressure spray can cause extremely serious injury.

OBSERVE ALL WARNINGS!

Before operating this unit, read and follow all safety warnings and instructions related to the usage of this equipment. READ, LEARN, and FOLLOW the Pressure Relief Procedure on Page 11 and understand all warnings on pages 2,3,4 & 5.

**All Service Procedures to be performed by an Authorized Airlessco Service Center ONLY.
NO MODIFICATIONS or alterations of any Airlessco Equipment or part is allowed.**

SAFETY WARNINGS

**HIGH PRESSURE SPRAY CAN CAUSE EXTREMELY SERIOUS INJURY.
OBSERVE ALL WARNINGS. THIS SPRAYER IS FOR PROFESSIONAL USE ONLY.**

INJECTION HAZARD

Fluids under high pressure from spray or leaks can penetrate the skin and cause extremely serious injury, including the need for amputation.

- **NEVER** point the spray gun at anyone or any part of the body.
- **NEVER** put hands or fingers over the spray tip. Do not use a rag or any other material over your fingers. Paint will penetrate through material and into the hand.
- **NEVER** try to stop or deflect leaks with your hand or body.
- **NEVER** try to "blow back" paint, this is not an air spray sprayer.
- **ALWAYS** have gun tip guard in place when spraying.
- **ALWAYS** lock gun trigger when you stop spraying.
- **ALWAYS** remove tip from the gun to clean it.
- **ALWAYS** follow the **PRESSURE RELIEF PROCEDURE**, as shown on page 11, before cleaning or removing the spray tip or servicing any system equipment.
- **ALWAYS** Be sure equipment safety devices are operating properly before each use.
- **ALWAYS** tighten all fluid connections before each use.

MEDICAL TREATMENT

If any fluid appears to penetrate your skin, get EMERGENCY CARE AT ONCE. DO NOT TREAT AS A SIMPLE CUT.

- * Go to an emergency room immediately.
- * Tell the doctor you suspect an injection injury.
- * Tell him what kind of material you were spraying with and have him read NOTE TO PHYSICIAN.

MEDICAL ALERT - Airless Spray Wounds

*If any fluid appears to penetrate your skin, get **EMERGENCY MEDICAL CARE AT ONCE. DO NOT TREAT AS A SIMPLE CUT.** Tell the doctor exactly what fluid was injected. Have him read the following "NOTE TO PHYSICIAN".*

NOTE TO PHYSICIAN:

*Injection in the skin is a traumatic injury. It is important to treat the injury **surgically** as soon as possible. **DO NOT DELAY** treatment to research toxicity. Toxicity is a concern with some exotic coatings injected directly into the bloodstream. **Consultation with a plastic surgeon or reconstructive hand surgeon may be advisable.***

GENERAL PRECAUTIONS

- **NEVER** alter equipment in any manner.
- **NEVER** spray highly flammable materials.
- **NEVER** allow another person to use sprayer unless they are thoroughly instructed on safety use and given this operators manual to read.
- **ALWAYS** wear a spray mask, gloves and protective eye wear while spraying.
- **ALWAYS** ensure fire extinguishing equipment is readily available and properly maintained.
- **NEVER** smoke while in spraying area.
- **NEVER** use around children.

NEVER LEAVE SPRAYER UNATTENDED WITH PRESSURE IN THE SYSTEM. FOLLOW PRESSURE RELIEF PROCEDURES ON PAGE 11.

SAFETY WARNINGS

TOXIC FLUID HAZARD

Hazardous fluid or toxic fumes can cause serious injury or death if splashed in eyes or on skin, inhaled or swallowed. Know the hazards of the fluid you are using. Store & dispose of hazardous fluids according to manufacturer, local, state & national guidelines. ALWAYS wear protective eyewear, gloves, clothing and respirator as recommended by fluid manufacturer.

ALWAYS INSPECT SPRAYING AREA

- **ALWAYS** keep spraying area free from obstructions.
- **ALWAYS** make sure area has good ventilation to safely remove vapors and mists.
- **NEVER** keep flammable material in spraying area.
- **NEVER** spray in vicinity of open flame or other sources of ignition.
- Spraying area must be at least 20 ft. away from the spray unit.

SPRAY GUN SAFETY

- **ALWAYS** set safety lock on the gun in "LOCKED" position when not in use and before servicing or cleaning.
- **NEVER** remove or modify any part of the gun.
- **ALWAYS REMOVE SPRAY TIP** when cleaning. Flush unit with **LOWEST POSSIBLE PRESSURE**.
- **ALWAYS** check operation of all gun safety devices before each use.
- Be very careful when removing the spray tip or hose from gun. A plugged line contains fluid under pressure. If the tip or line is plugged, follow the **PRESSURE RELIEF PROCEDURE** as outlined on page 11.

TIP GUARD

ALWAYS have the tip guard in place on the spray gun while spraying. The tip guard alerts you to the injection hazard and helps prevent accidentally placing your fingers or any part of your body close to the spray tip.

SPRAY TIP SAFETY

Use extreme caution when cleaning or changing spray tips. If the spray tip clogs while spraying, engage the gun safety latch immediately.

- **ALWAYS** follow the **PRESSURE RELIEF PROCEDURE** and then remove the spray tip to clean it.
- **NEVER** wipe off build up around the spray tip.
- **ALWAYS** remove tip & tip guard to clean **AFTER** pump is turned off and the pressure is relieved by following the **PRESSURE RELIEF PROCEDURE**.

KEEP CLEAR OF MOVING PARTS

Keep clear of moving parts when starting or operating the sprayer. Do not put your fingers into any openings to avoid amputation by moving parts or burns from hot parts.

Precaution is the best insurance against an accident.

When starting the engine, maintain a safe distance from moving parts of the equipment.

Before adjusting or servicing any mechanical part of the sprayer, follow the **PRESSURE RELIEF PROCEDURE**, and remove the ignition cable from the spark plug to prevent accidental starting of the sprayer.

LABELING

Keep all labels on the unit clean and readable. Replacement labels are available from the manufacturer.

SAFETY WARNINGS

GROUNDING

Ground the sprayer and other components in the system to reduce the risk of static sparking, fire or explosion which can result in serious bodily injury and property damage.

Always ground all of these components:

- **Sprayer:** Connect a ground wire and clamp (supplied) to a true earth ground.
- **Fluid Hose:** use only grounded hoses.
- **Spray gun or dispensing valve:** grounding is obtained through connection to a properly grounded fluid hose and pump.
- **Object being sprayed:** according to your local code.
- All solvent pails used when flushing should only be metal pails which are conductive.

Once each week, check electrical resistance of hose (when using multiple hose assemblies, check overall resistance of unpressurized hose must not exceed 29 megohms (max) for any coupled length or combination of hose lengths. If hose exceeds these limits, replace it immediately.

Never exceed 500 Ft. (150 m.) overall combined hose length to assure electrical continuity.

AVOID COMPONENT RUPTURE

This sprayer operates at 3000 psi (205 bar). Always be sure that all components and accessories have a maximum working pressure of at least 3000 psi to avoid rupture which can result in serious bodily injury including injection and property damage.

- **NEVER** leave a pressurized sprayer unattended to avoid accidental operation of it which could result in serious bodily injury.
- **ALWAYS** follow the PRESSURE RELIEF PROCEDURE whenever you stop spraying and before adjusting, removing or repairing any part of the sprayer.
- **NEVER** alter or modify any part of the equipment to avoid possible component rupture which could result in serious bodily injury and property damage.
- **NEVER** use weak, damaged or non-conductive paint hoses. Do not allow kinking or crushing of hoses or allow it to vibrate against rough, sharp or hot surfaces. Before each use, check hoses for damage and wear and ensure all fluid connections are secure.
- **REPLACE** any damaged hose. NEVER use tape or any device to mend the hose.
- **NEVER** attempt to stop any leakage in the line or fittings with your hand or any part of the body. Turn off the unit and release pressure by following PRESSURE RELIEF PROCEDURE on page 11.
- **ALWAYS** use approved high pressure fittings and replacement parts.
- **ALWAYS** ensure fire extinguishing equipment is readily available and properly maintained.

WARNING

Do not use halogenated solvents in this system. The prime valve, 2 gun manifold and most airless guns have aluminum parts and may explode. Cleaning agents, coatings, paints or adhesives may contain halogenated hydrocarbon solvents. DON'T TAKE CHANCES! Consult your material suppliers to be sure. Some of the most common of these solvents are: Carbontetrachloride, Chlorobenzene, Dichloroethane, Dichloroethyl Ether, Ethylbromide, Ethylchloride, Tetrachloroethane. Alternate valves and guns are available if you need to use these solvents.

SAFETY WARNINGS

FLUSHING

Reduce the risk of injection injury, static sparking or splashing by following the specific cleaning procedure on page 7.

- **ALWAYS** follow the PRESSURE RELIEF PROCEDURE on page 11.
- **ALWAYS** remove the spray tip before flushing. Hold a metal part of the gun firmly to the side of a metal pail and use the lowest possible fluid pressure during flushing.
- **NEVER** use cleaning solvents with flash points below 140° F. Some of these are: acetone, benzene, ether, gasoline and naphtha. Consult your supplier to be sure.
- **NEVER** smoke in the spraying/cleaning area.

PREVENT STATIC SPARKING FIRE/ EXPLOSIONS

ALWAYS be sure all equipment and objects being sprayed are properly grounded. Always ground sprayer, paint bucket and object being sprayed. See "grounding" on page 4 for detailed grounding information.

Vapors created when spraying can be ignited by sparks. To reduce the risk of fire, always locate the sprayer at least 20 feet (6 m.) away from the spray area. Do not plug in or unplug any electrical cords in the spray area, this can create sparks when there is any chance of igniting vapors still in the air. Follow the coating & solvent manufacturers safety warnings and precautions.

Use only conductive fluid hoses for airless applications. Be sure gun is grounded through hose connections. Check ground continuity in hose & equipment. Overall (end to end) resistance of unpressurized hose must not exceed 29 megohms for any coupled length or combination of hose length. Use only high pressure airless hoses with static wire approved for 3000 psi.

GAS ENGINE PRECAUTIONS

Locate unit 25 feet away from spray area in well ventilated area.

- **NEVER** operate in closed buildings unless exhaust is piped outside.
- **NEVER** allow hose to lay against engine mufflers or hot parts.
- **NEVER** refill fuel tank while engine is hot or is running.

Important: United States Government safety standards have been adopted under the Occupational Safety & Health Act. These standards, particularly the General Standards, Part 1910, & the Construction Standards, part 1926 should be consulted.

WHEN SPRAYING & CLEANING WITH FLAMMABLE PAINTS OR PAINT THINNERS:

1. When spraying with flammable liquids, the unit must be located a minimum of 25 feet away from the spraying area in a well ventilated area. Ventilation must be sufficient enough to prevent the accumulation of vapors.
2. To eliminate electrostatic discharge, ground the spray unit, paint bucket and spraying object. Use only high pressure airless hoses approved for 3000 psi which is conductive.
3. Remove spray tip before cleaning gun and hose. Make contact of gun with bucket and spray without the tip in a well ventilated area, into the grounded steel bucket.
4. Never use high pressure in the cleaning process. USE MINIMUM PRESSURE.
5. Do not smoke in spraying/cleaning area.

FLUSHING

Read prior to using your sprayer

1. New Sprayer

Your Airlessco unit was factory tested in an antifreeze solution which was left in the pump. Before using oil-base paint, flush with mineral spirits only. Before using water-base paint flush with soapy water, then do a clean water flush.

2. Changing Colors

Flush with a compatible solvent such as mineral spirits or water.

3. Changing from water-base to oil-base paint.

Flush with soapy water, then mineral spirits.

4. Changing from oil-base to water-base paint.

Flush with mineral spirits, followed by soapy water, then do a clean water flush.

5. Storage

Oil-base paint: Flush with mineral spirits.

Water-base paint: Flush with water, then mineral spirits and leave the pump, hose and gun filled with mineral spirits. For longer storage, use mixture of mineral spirits and motor oil (half & half). Shut off the sprayer, follow Pressure Relief Procedure on page 11 to relieve pressure and make sure prime valve is left OPEN.

6. Start up after storage

Before using water-base paint, flush with soapy water and then do a clean water flush. When using oil-base paint, flush out the mineral spirits with the material to be sprayed.

HOW TO FLUSH

FIGURE 1

REMOVE
SPRAY
TIP



FIGURE 2

PRESSURE CONTROL
KNOB



PRIME VALVE &
PRESSURE RELIEF
VALVE

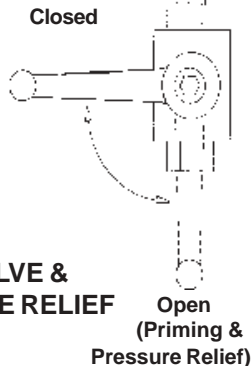

FIGURE 3

Choke Lever
Fuel Valve
Throttle Lever

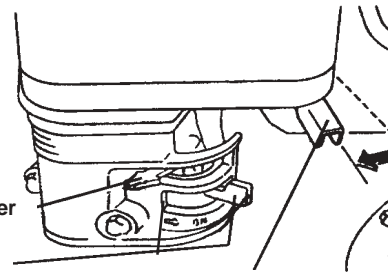

FIGURE 4

MAINTAIN FIRM
METAL TO METAL
CONTACT BETWEEN
GUN AND CONTAINER



1. Be sure the gun safety latch is engaged and there is no spray tip in the gun. Refer to Fig. 1. Refer to your separate instruction manual provided with your gun on its safety features and how to engage safety latch.
2. Pour enough clean, compatible solvent into a large, empty metal pail to fill the pump and hoses.
3. Place the suction tube into the pail or place the pail under the pump.
4. Turn the pressure control knob to low pressure. Refer to Fig. 2.
5. Open the prime valve to the open - "Priming Position". This will allow an easy start. Refer to Fig. 2.
6. Turn the engine ON/OFF switch to ON.
7. Move the choke to the closed position as per Fig. 3.
8. Move the throttle lever slightly to the left as per Fig. 3.
9. Turn the fuel valve ON as per Fig. 3. Pull the start rope. Pull the engine over against compression stroke and then let the rope rewind slowly into the starter. Pull firmly and rapidly to start the engine. Do NOT drop the rope. Hold onto the handle while rewinding, or the rope may rewind improperly and jam the assembly. If the engine does not start, open the choke half way. If the engine floods, open the choke all the way and continue cranking.
10. After the engine is warm, gradually open the choke lever, increase the RPM of engine by moving throttle all the way to the left. Close the prime valve. Refer to Fig. 2.
11. Point the gun into the metal pail and hold a metal part of the gun firmly against the pail Refer to fig. 4.

WARNING

To reduce the risk of static sparking, which can cause fire or explosion, always hold a metal part of the gun firmly against the metal pail when flushing. This also reduces splashing. Refer to Fig. 4.

12. Disengage the gun safety latch and squeeze the gun trigger. At the same time, slowly turn the pressure control knob clockwise just enough to move liquid at low pressure.
13. Allow the pump to operate until clean solvent comes from the gun.
14. Release the trigger and engage the gun safety latch.
15. If you are going to start spraying, place the pump or suction tube into the supply container. Release the gun safety latch and trigger the gun into another empty, metal container, holding a metal part of the gun firmly against the metal pail (Fig. 4) and force the solvent from the pump and hose. When paint starts coming from the gun, turn pressure control knob to minimum pressure, place prime valve in prime (open) position and engage the gun safety latch.
16. If you are going to store the sprayer, remove the suction tube or pump from the solvent pail force the solvent from the pump and hose. Engage the gun safety latch and refer to the "Storage" Procedure on page 6. Step 5.
17. Whenever you shut off the sprayer follow the Pressure Relief Procedure warning on page 11.

SETTING UP

1. Attach handle assembly.

- a. Choose which side the handle will be mounted. The handle can be affixed over the single wheel assembly or on the opposite side towards the large tires. The latter is the usual set up.

FOR SURESTRIP 6000 (REFER TO FIG. 20)

- b. Line up the mounting holes on the front forks of the handle with the mounting holes on the frame.
- c. Insert the two bolts through the front forks and the frame. Slide on washer and loosely screw on the nuts. Do not fully tighten the nuts.
- d. Place the four bolts in the frame and handle adjustment slots, slide on washer and loosely tighten the nuts. Do not fully tighten the nuts.
- e. Adjust handle the preferred height and tighten all six mounting bolts.

FOR SURE STRIPE 4500 (REFER TO FIG. 28)

- b. Slide plate (Item 11) over clamp (Item 12).
- c. Place clamp with plate over frame, so that the holes on the clamp line up with the mounting holes on the frame (Item 43). This should be done for both plate and clamps sets.
- d. Insert handle forks into clamp and frame mounting holes.
- e. Thread screws (Item 13) into clamp and tighten to secure handle to desired height.

2. Install the gun arm assembly.

- a. Select the location that the gun arm will be place. The location depends on the type striping to be done. (See Linestriping Operations). The standard location is in the right front position.
- b. Position clamp assembly over the selected gun arm location and place the gun arm assembly into the frame mounting hole and the clamp assembly.
- c. Tighten clamp assembly handle to secure the gun arm assembly.

3. Fill the Packing Nut/Wet Cup 1/3 full with Airlessco Throat Seal Oil (TSO) supplied. Figure 5 →

4. Check the Engine Oil Level.

- a. Unscrew the oil fill plug. The dipstick is attached to the plug.
- b. Without threading the plug into place, check to be sure the oil is up to the top mark on the dipstick.
- c. If oil is needed, refer to engine manual.

NOTE: **Unit is shipped WITHOUT OIL in engine.**

5. Fill the Fuel Tank

WARNING

Fuel spilled on a hot surface can cause a fire or explosion and cause serious bodily injury and property damage. Always shut off the engine and let it cool before filling the tank, and carefully follow Steps a-c below, being sure not to spill any fuel.

- a. Close the fuel shutoff valve.
- b. Use only clean, fresh, well-known brands of unleaded regular grade gasoline.
- c. Remove the fuel cap and fill tank, Be sure the air vent in the fill cap is not plugged so fuel can flow to the carburetor, then replace the cap.

6. Flush the sprayer.

See "Flushing" page 6 & 7. Your new pump was factory tested in an ant-freeze solution and it must be flushed before using.

NOTE: **Prior to striping, see Linestriping Operations for correct gun arm set up, to get proper sized lines.**

FIGURE 5

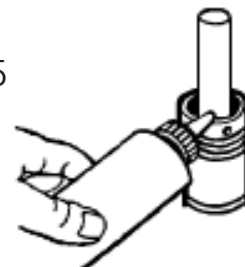

STARTING UP

1. Learn the controls.

Pressure Control Knob - Used to adjust pressure only. Turn clockwise to increase pressure and counterclockwise to decrease pressure. (See Fig. 6)

Prime & Pressure Relief Valve - Turn to OPEN position (see Fig. 7) to prime the pump. Turn to the CLOSED position to spray.

FOLLOW THE "PRESSURE RELIEF PROCEDURES" ON PAGE 11 WHENEVER YOU:

- are instructed to relieve pressure
- stop spraying
- checking or servicing any of the system equipment.
- **install or clean the spray tip.**

HANDLE THE SPRAY SYSTEM AS YOU WOULD A LOADED FIREARM!!

⚠ CAUTION

Do not start engine without fluid pump having enough fluid so that it can be primed. Running fluid pump dry will decrease life of the pumps packings.

2. Prepare the Material

- Prepare the material according to the manufacturer's material recommendations.
- Place the pump or suction tube into the material container.

3. Starting the Sprayer (see Fig. 6 & 7 above)

- Prime Valve must be open to the priming position.
- Pressure Control Knob must be in the low pressure position.
- Follow the procedure under "How to Flush", page 7, Steps 6 through 12.

WARNING

To stop the unit in an emergency or before performing any service or maintenance procedure follow the Pressure Relief Procedure on page 11 to relieve the fluid pressure.

FIGURE 6

PRESSURE CONTROL KNOB

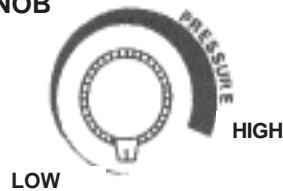
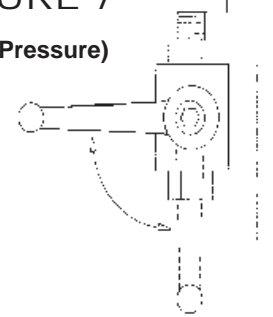

FIGURE 7

Closed (Pressure)



4. Prime the Pump

- Allow pump to operate until paint comes from gun.
- Release the trigger and engage the gun safety latch.
- Turn Prime Valve OPEN to the prime position ensuring the pressure is released from the system.
- Turn Pressure Control Knob to minimum pressure.
- Install spray tip onto gun.
- Close the prime valve to the pressure position.
- Turn the pressure control knob to desired spray pressure.
- Disengage the gun safety lock and you are ready to start spraying.

WARNING

If you spray into the paint bucket, always use the lowest spray pressure and maintain firm metal to metal contact between gun and container. See page 7, Fig. 4.

5. Adjusting the Pressure

- Turn the Pressure Control Knob clockwise to increase pressure and counterclockwise to decrease pressure.
- Always use the lowest pressure necessary to completely automatize the material.

⚠ CAUTION

Operating the sprayer at higher pressure than needed wastes material, causes early tip wear and shortens sprayer life.

- If more coverage is needed use a larger tip rather than increasing the pressure.
- Check the spray pattern. The tip size and angle determines the pattern width and flow rate.

STARTING UP

6. Cleaning a Clogged Tip.

WARNING

Always follow the Pressure Relief Procedure before performing any service or maintenance procedure.

WARNING

Never hold your body, fingers, or hand in front of the spray tip when cleaning or checking it for a cleared tip. Always point the gun forward or into a waste container when checking to see if the tip is cleared or when using a self-cleaning tip.

- a. Follow the Pressure Relief Procedure.
- b. Clean the front of the tip frequently (with a toothbrush only) during the day to keep material from building up and clogging the tip.
- c. To clean and clear a tip if it clogs, refer to the separate instruction manual received with your gun and nozzle.

There is an easy way to keep the outside of the tip clean from material build-up:

Everytime you stop spraying, for even a minute, lock the gun and submerge the gun nozzle into a small bucket of thinner compatible with the material sprayed.

Thinner will dissolve the build up of paint on the outside of the tip, tip guard and gun much more effectively than if the paint dries out completely.

WARNING

With a Clogged standard flat tip - clean only after the tip is removed from the gun. Follow the Pressure Relief Procedure

7. When shutting Off the Sprayer

- a. Whenever you stop spraying, even for a short break, follow the Pressure Relief Procedure.
- b. Clean the tip and gun as recommended by your separate gun instruction manual.
- c. Flush the sprayer at the end of each work day if the material you are spraying is waterbased, or if it could harden in the sprayer overnight. See "Flushing" page 6 and 7. Use a compatible solvent to flush, then fill the pump and hoses with an oil based solvent such as mineral spirits.
- d. For long term shutdown or storage, refer to page 6.

DAILY MAINTENANCE

1. Always stop the pump at the bottom of its stroke when you take a break or at the end of the day. This helps keep material from drying on the rod and damaging the packings.
2. Keep the displacement pump packing nut/wet cup 1/3 full of TSO (Airlessco Throat Seal Oil) at all times. The TSO helps protect the packings and rod.
3. **Inspect the packing nut daily.** Your Airlessco pump has a patented "Triple Life Packing System". **Packing life will be extended a minimum of 3 times if**

the following Packing Adjustment Procedure is followed:

Inspect the packing nut daily. If seepage of paint is going into the packing nut and/or movement of the piston upward is found (while not spraying), the packing nut should be tightened enough to stop leakage only, but not any tighter.

Overtightening will damage the packings and reduce the packing life to the life of other piston pumps.

4. Lubricate Connecting Rod Pin every 3 months with SAE 30 W oil or annually with bearing grease.

PRESSURE RELIEF PROCEDURE

To avoid possible serious bodily injury, including injection, always follow this procedure whenever the sprayer is shut off, when checking or servicing it, when installing or changing the tips, whenever you stop spraying or when you are instructed to relieve the pressure.

1. Engage gun safety latch. Refer to separate instruction manual provided with your gun on its safety features and how to engage safety latch.

2. Turn engine off.



3. Disengage safety latch & trigger gun to relieve residual fluid pressure. Hold metal part of the gun in contact with grounded metal pail.

4. Re-engage gun safety latch

5. Turn Prime/Pressure Relief Valve as shown open (priming) to relieve fluid pressure.

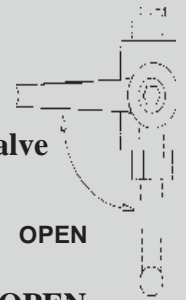

* Leave prime valve OPEN until you are ready to spray again.

IF THE SPRAY TIP OR HOSE IS CLOGGED:

Follow Step 1 through 5 above. Expect paint splashing into the bucket while relieving pressure during Step 5. If you suspect that pressure hasn't been relieved due to damaged prime/pressure relief valve or other reason, engage gun safety latch and take your sprayer to an authorized Airlessco Service Center for service. *Always follow recommended pressure & operating instructions.

HOSES

Tighten all fluid connections securely before each use. High pressure fluid can dislodge a loose coupling or allow high pressure spray to be emitted from the coupling and result in an injection injury or serious bodily injury.

Use only a hose that has a spring guard. The spring guard helps protect the hose from kinks or other damage which could result in hose rupture and cause an injection injury.

NEVER use a damaged hose which can result in hose failure or rupture and cause an injection injury or other serious bodily injury or bodily damage. Before each use, check entire hose for cuts, leaks, abrasions or bulging of cover, or damage or movement of couplings. If any of these conditions exist, replace the hose immediately. Never use tape or any device to try to mend the hose as it cannot contain the high pressure fluid. NEVER ATTEMPT TO RECOUP THE HOSE. High pressure hoses are not recoupable. Help prevent damage to the hose by handling and routing carefully. Do not move the sprayer by pulling it with the hose.

LINE STRIPING OPERATION

1. Choose handle location.

The choices are, installing the handle opposite of the single wheel assembly (standard set up) or placing the handle directly over the single wheel assembly. The handle location is really a matter of personal preference, however having the handle away from the single wheel assembly allows for easier loading/unloading from a van or truck on the 6000 model.

2. Choose the gun arm position.

There are six holes in the frame on the 6000 & four holes on the 4500 for mounting the gun arm. In a standard set up (handle away from the single wheel assembly), the gun arm would be mounted in one of the two mounting holes near the single wheel. This allows for an easier visual check for straight line striping and for basic arc striping. Regardless of the handle position, use the center mounting holes, near the axle (6000 only), for precise circles and arcs. The mounting holes under the handle are usually used when the handle has been placed over the single wheel. Experiment with different combinations to find the set up that you prefer.

3. Setting up the guns.

- a. Ensure that striping tips are in the guns.
- b. Pick a tip size for the desired line width.
Example: a 217ST tip for a four inch line.
- c. Place gun into the gun holder, so that the top of the taper on the gun handle is flush with the edge of the gun holder.
- d. Set gun height for the desired line width. Adjust height by loosening the small black handle on the gun holder assembly and slide the gun arm to the correct height. Now tighten the handle. This will require some experimentation to find the correct height. It is suggested that tape, or some other method is used to mark the height of commonly used settings.
- e. Set spacing between the two guns by loosening the black handle on the gun arm. Slide to the desired width and tighten.
- f. Attach the swivel heads to the guns if painting curbs or wide stripes.
- g. Angle the guns slightly forward. This allows the spray pressure from the guns to help blow dirt and debris out of the path of the new stripes.

4. Cable Tension Adjustment.

Once the handle and gun arm assemblies are set up to the preferred positions, pressurize the unit and trigger each gun to ensure that they activate and release correctly. If not, adjust the cable tension as follows:

- a. Locate the adjustment knobs on the base of the gun trigger, where the cable connects to the gun trigger assembly.
- b. Loose the locking nut and move the adjusting screw until the slack has been removed from the cable.

- c. Tighten locking nut and retest gun triggers for proper function.

Note: *There is an additional cable adjustment where the cable attaches to the gun holder assembly. Use only if the gun trigger adjustment is insufficient.*

5. Align caster wheel assembly. (6000 only)

STRAIGHT LINES

- a. Loosen the two ratchet handles on the caster wheel assembly, just enough to be able to move the assembly by hand. Lift the ratchet handle to move the handle without turning the attached bolts, then press down and turn handle counterclockwise to loosen.
- b. Place the turnbuckle over the two mounting nubs on the frame.
- c. Pressurize the unit with water and Airlessco's Pump Conditioner and spray out several lines with the caster assembly in the locked position. Use the turnbuckle to fine tune the alignment of the wheels, until the stripes are straight.



IMPORTANT: *Loosen ratchet handles prior to any turnbuckle adjustment.*

- d. Tighten the jam nuts on the turnbuckle to affix the turnbuckle length for future reference.
- e. Tighten the ratchet handles.

CURVES AND ARCS

Basically the same as above, except the caster wheel assembly is set at angle. The caster assembly can be adjusted to 30 degrees either side of straight ahead. If you have arcs that you paint regularly, purchase additional turnbuckles (PN. 136-163) and keep them set to those arc sizes.

6. Miscellaneous Operations.

- a. **CURBS:** Adjust gun to desired height and turn swivel head towards curb.
- b. **WIDE STRIPES:** Install wider fan striping tips and raise the gun height to achieve the desired width line. Also angle guns slightly towards each other to get an even coat of paint.
- c. **STENCILS:** Install standard spray tip on the outer gun. Remove this gun from the gun holder and spray out the stencils.
- d. **STANDARD PAINTING:** Same as stencils, but use additional paint hose as required.

7. Loading and Unloading. (6000 only)

Loading and unloading can be accomplished by one person, when the machine is in the standard set up, by rotating the caster wheel assembly all the way forward and leaning back on the handles. For taller vehicles, an accessory wheel assembly is available. This wheel assembly attaches to the handles, allowing the machine to rock farther back, thus lifting the caster wheels much higher.

007X & 007XL SPRAY GUNS

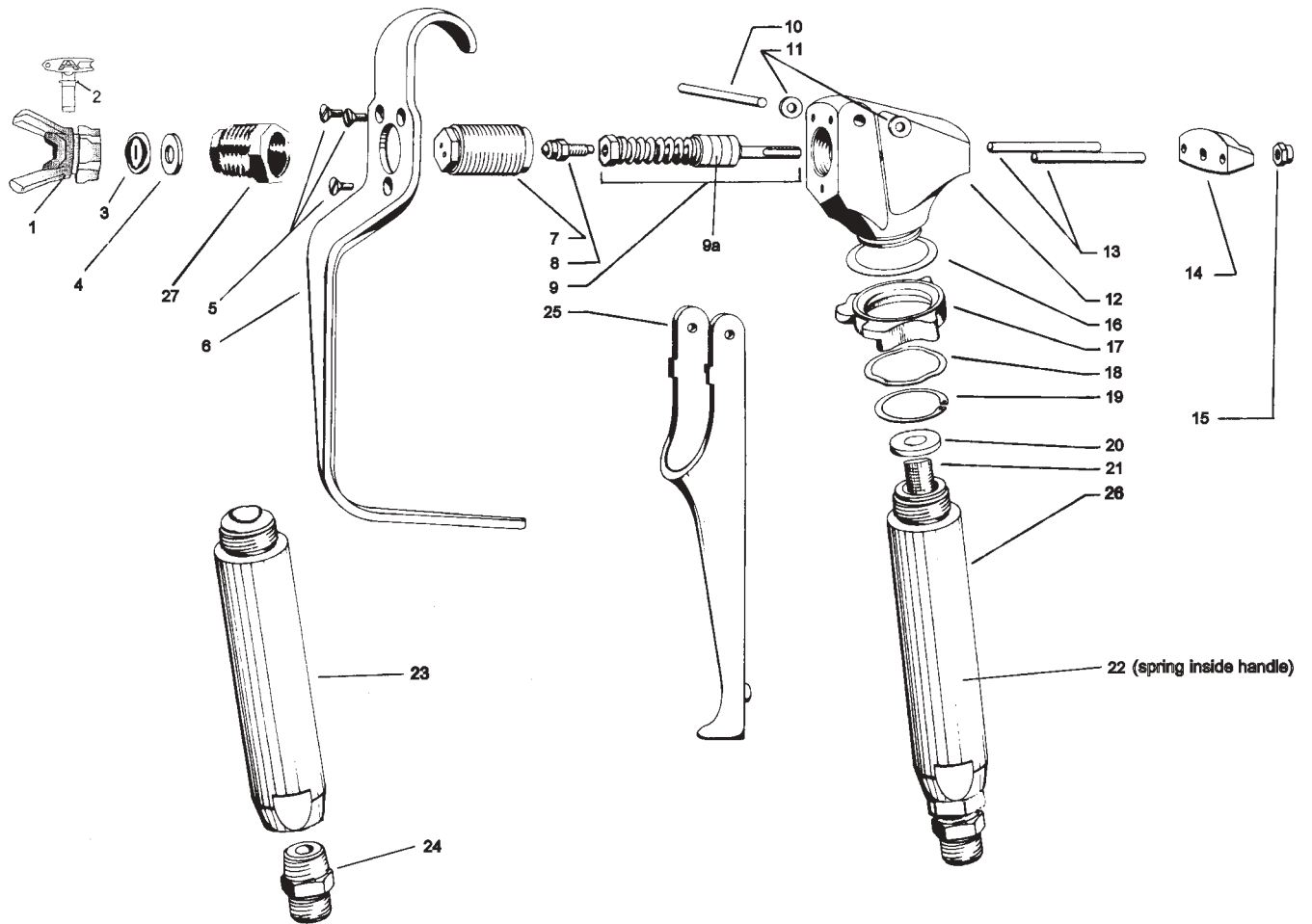

SPRAY GUN PARTS LIST

Item No.	Part No.	Description	Item No.	Part No.	Description
1	561-001	Rev-Guard	15	120-021	Nut
2	560-xxx	Rev-Tip	16	120-056	Washer
3	561-025	Rev-Tip Seal-metal	17	120-048	Safety Latch or Trigger Lock
4	561-026	Rev-Tip Seal-O-ring	18	120-055	Wave Washer
5	120-023	Screw (3)	19	120-049	Retaining Ring
6	120-005	Guard	20	120-082	Seal
7	120-035	Valve Seat Complete	21	120-090CX	Filter-Complete-Coarse
8	120-037	Valve Ball with Holder		120-090FX	Filter-Complete-Fine
9	120-011	Valve Spring Unit	22	120-088	Spring
9a	120-033	Seals Teflon (2)	23	120-087	Handle Complete 007X
10	120-022	Trigger Pin	24	115-019	Connector
11	120-046	Washer (2)	25	120-044	Trigger
12	120-002	Gun Head	26	120-085	Handle with Swivel 007XL
13	120-045	Retainer Pin (2)	27	032-012	F/G Thread Adaptor
14	120-020	Retainer			

007X & 007XL SPRAY GUN

Attach spray gun to hose and tighten fittings securely. Set the gun safety latch. (Also may be called gun safety lock) The gun safety latch should always be set when the gun is not being triggered.

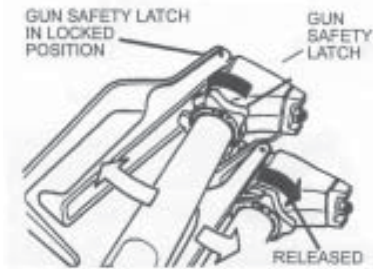

ADJUSTING SPRAY GUN

Hold gun with trigger locked (25) and push trigger against the lock (17). Then adjust nut (15) so that the retainer (14) will move freely back and forth approximately 1/32" to allow valve spring unit (9) to seat the valve ball (8).

⚠ IMPORTANT: Readjust nut (15) periodically for wear of valve seat (7) and valve ball (8); otherwise, leakage will occur.

TO REPLACE THE VALVE BALL HOLDER (8)

KIT #2-007

- | | |
|-------------------------|---------------------|
| 3 Tip Washers | 1 Valve Seat (7) |
| 1 Valve Ball Holder (8) | 2 Seals-Teflon (9a) |

Dismantling:

1. Unscrew Rev-Guard and remove spray tip and seal.
2. Unscrew valve seat (7) with 1/2" socket wrench.

⚠ CAUTION

When removing and replacing valve seat (7), hold the trigger (25) in the open position so that the valve ball (8) is lifted off the valve seat. Failure to lift the ball off the seat will result in a scratched leaky valve.

3. Unscrew valve ball (8) together with the brass part of the assembly (9). Do not pull on the parts or the packing may get damaged.
4. Unscrew the valve ball (8) from the brass part of the assembly (9).

Reassembling is done in reverse sequence. Screw the new valve ball with holder (8) into the brass part (9).

⚠ CAUTION

Tighten valve ball and brass part on threaded end of the shaft by hand until you feel a positive stop. Do not tighten with a wrench since this could result in breaking the shaft.

Note: It is recommended that you change the valve seat (7) and valve ball (8) at the same time.

REPLACING THE VALVE SPRING UNIT (9)

KIT#3-007

- | | |
|-------------------------|-------------------------|
| 3 Tip Washers | 1 Valve Seat (7) |
| 1 Valve Ball Holder (8) | 1 Valve Spring Unit (9) |

1. Repeat dismantling procedure as outlined above under Steps 1 through 3.
2. Unscrew nut (15), remove retainer (14) with retainer pins (13) and push shaft of the valve spring unit (9) out of the gun head (12).
3. Clean gun head (12) bore with solvent and small brush. Do not use any sharp objects to scrape away dried paint, as they would cause leakage around the seal.

Reassembling is done in reverse sequence.

⚠ IMPORTANT: When reassembling, install valve spring unit (9) with spring loose.

Push firmly into gun head by hand. Install retainer pins (13), retainer (14) and nut (15) loosely onto valve spring unit (9). By hand turn front of valve spring unit clockwise, tightening the valve spring unit until you feel a positive stop. At that point, continue tightening the valve spring another 1/8 turn expanding the Teflon seals against body of gun.

⚠ CAUTION

Do not tighten beyond 1/8 turn as this can result in breaking the valve spring unit shaft. Continue reassembly and adjustment as described above.

CLEANING 007 SPRAY GUN

Immediately after the work is finished, flush the gun out with a solvent. Brush pins (13) with solvent and oil them lightly so they will not collect dried paint.

TO REMOVE CLOGS- REVERSIBLE TIP

1. Lock gun trigger.
2. Turn Rev-Tip handle 180 degrees.
3. Disengage trigger lock and trigger gun into pail.
4. If the Rev-Tip handles appears locked (resists turning) loosen the retaining nut. Then handle will now turn easily.
5. Engage trigger lock and return handle to the spray position.

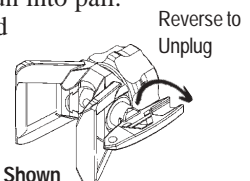

CLOGGED FLAT TIP

Should the spray tip become clogged, relieve pressure from hoses by following the "Pressure Relief Procedure" in Machine Manual, secure the gun with safety lock (17), take off Guard, take out the tip, soak in appropriate solvent & clean with a brush. (Do not use a needle or sharp pointed instrument to clean the tip. The tungsten carbide is brittle and can chip.)

CLEANING FILTER

To clean the filter, use a brush dipped in as appropriate solvent. Change or clean filters at least once a day. Some types of latex may require a filter change after four hours of operation.

AIRLESS SPRAY GUN OPERATION

<u>DEFECTS</u>	<u>CAUSE</u>	<u>CORRECTION</u>
Coarse spray	Low pressure	Increase the pressure.
Excessive fogging (overspray)	High pressure Material too thin	Reduce the pressure to satisfactory pattern distribution. Use less thinner.
Pattern too wide	Spray angle too large	Use smaller spray angle tip.
Pattern too narrow	Spray angle too small	Use larger spray angle tip. (If coverage is OK, try tip in same nozzle group)
Too much material	Nozzle too large Material too thin Pressure too high	Use next smaller nozzle. Reduce pressure.
Too little material	Nozzle too small Material too thick	Use next larger nozzle.
Thin distribution in center of pattern "horns"	Worn tip Wrong tip	Change for new tip. Use nozzle with a narrow spray angle.
Thick skin on work	Material too viscous Application too heavy	Thin cautiously. Reduce pressure and/or use tip in next smaller nozzle group.
Coating fails to close & smooth over	Material too viscous	Thin cautiously.
Spray pattern irregular, deflected	Orifice clogged Tip damaged	Clean carefully. Replace with new tip.
Craters or pock marks, bubbles	Solvent balance	Use 1 to 3% "short" solvents & remainder "longsolvents". (This is most likely to happen of low on work with material viscosity, lacquers etc.)
Clogged screens	Debris in paint Coarse paint pigments Incompatible paint mixture & thinners.	Clean screen. Use coarse gun filter screen. Use coarser screen for larger orifice tips. If thinner was added, test to see if a drop on top of paint mixes or flattens out on the surface. If not, try different thinner in a fresh batch of paint.

TEST THE PATTERN

Good, full



Spotty Pattern
Increase Pressure.



LINE STRIPING TIP CHART

NOTE: Striping Tips should not be used for regular spraying.

Rev-Tip™ for Striping

Part Number 562-xxxST

TIP IDENTIFICATION:

- 1st 3-digits identifies it as a **REV-TIP™** for airless line striping (Part Number 562-xxxST).
- 4th digit is the fan width - the number is half the fan width, e.g., 5 means a 10' fan.
- 5th and 6th digits are for the orifice size and is measured in thousandths of an inch, e.g., 17 = 0.017 inch.

The higher the number, the larger the tip.

Rev-Tip™ for Striping		STRIPING TIP - ORIFICE SIZE (Inches)											
Fan Width (6" from surface)		.009	.011	.013	.015	.017	.019	.021	.023	.025	.027	.031	.035
1-2	25-51			113ST	115ST	117ST	119ST						
2-4	51-102				215ST	217ST	219ST	221ST					
4-6	102-152				315ST	317ST	319ST	321ST					
6-8	152-203												
Striping Paint				Oil Base	Oil Base	Latex	Latex	Latex	Latex	Latex	Latex		

	.009	.011	.013	.015	.017	.019	.021	.023	.025	.027	.031	.035
Water Flow Rate (gpm) <small>(water @ 2000psi, 135 bar)</small>		.12	.18	.24	.31	.38	.47	.57	.67	.77	1.03	1.31
(lpm)		.49	.69	.91	1.17	1.47	1.79	2.15	2.54	2.96	3.90	4.98
Paint Flow Rate (gpm) <small>(latex paint @ 2000psi, 135 bar/1.35 spec. gr.)</small>		.10	.15	.21	.27	.33	.40	.49	.58	.66	.88	1.12
(lpm)		.38	.57	.79	1.02	1.25	1.51	1.85	2.20	2.50	3.33	4.24
Pump Minimum Output* (gpm)		.25	.25	.33	.40	.50	.60	.75	.88	1.0	1.25	1.5
(lpm)		1.0	1.0	1.25	1.5	1.9	2.3	2.8	3.3	3.8	4.7	5.7

*Pump will support tip worn to next larger size.

TIP REPLACEMENT:

During use, high pressure will cause the orifice to grow larger. This destroys the pattern or will leave tailing or two heavy lines on the outside of the pattern. **REPLACE SPRAY TIP FREQUENTLY!**

OIL AND LUBRICATION PROCEDURE

FIGURE 8

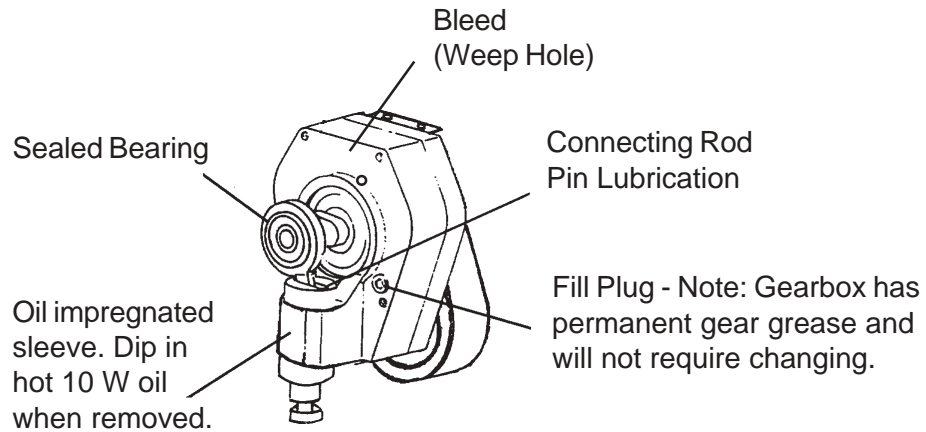

TROUBLESHOOTING

PROBLEM	CAUSE	SOLUTION
There is spitting from the gun.	The fluid supply is low or empty.	Refill the supply container.
	Air entrapped in the fluid pump or hose.	Check for loose connections on the siphon assembly, tighten, then reprime pump.
Paint leaks into the wet cup.	The packing nut/wet cup is loose.	Tighten just enough to stop leakage.
	The upper packings are worn or damaged. Worn Piston Rod.	Replace the packings. See page 20. Replace Piston Rod
The engine operates, but the paint pump doesn't cycle.	The pressure setting is too low.	Increase the pressure. See page 9.
	The clutch is not engaged.	See Troubleshooting "Clutch does not engage" page 22.
The engine and displacement pump operates, but paint pressure is too low or none.	The displacement pump is seized.	Service the pump. See pgs. 18 & 19
	The pressure setting is too low. The tip or gun filter is clogged. The tip is worn. The fluid displacement pump filter is clogged. There is a large pressure drop in the fluid hose.	Increase the pressure, see page 9. Remove the tip and/or filter and clean them. Replace Tip. Clean the filter. Use a larger diameter hose.
The displacement pump operates, but the output is too low on the downstroke or both strokes.	The lower check valve ball is not seating properly.	Service the lower check valve see page 19.
The displacement pump operates, but the output is too low on the upstroke.	The upper check valve ball is not seating properly.	Service the upper check valve per page 19.
	The lower packings are worn or damaged.	Replace the packings. See page 20.
Clutch does not engage. Clutch slippage.		See Troubleshooting page 22. Call Authorized Service Center.
Engine stops		Refer to Engine Manual.

SERVICING FLUID PUMP

Note: Check everything in the Troubleshooting Chart before disassembling the sprayer.

FLUID PUMP DISCONNECT

1. Flush out the material you are spraying, if possible.
2. Follow the Pressure Relief Procedure on Page 11. Stop the pump in the middle of the down stroke.
3. Remove the suction tube and fluid hose (if so equipped) from the fluid pump.
4. Remove 2 retaining rings and slip the sleeve of the coupling down and remove both coupling halves. This will disconnect fluid pump from the connecting rod.
5. Unscrew the two tie rod locknuts.
6. Pull the pump off the tie rods.

FLUID PUMP REINSTALL

1. Loosen the packing nut and extend piston rod to a full up position. Slip sleeve (189-047) over the piston rod.
2. Make sure that the spacer tubes (301-048) are in place.
3. Connect the connecting rod with the fluid pump by installing coupling halves (189-046). Slide sleeve over coupling halves. Secure with retaining ring (189-048).
4. Secure the fluid pump housing to the tie rods (100-328) and screw locknuts with washers on loosely.
5. Tighten the tie rod locknuts evenly to 30 ft. lb.
6. Reconnect fluid hose and suction tube (if so equipped).

NOTE: After all the rod locknuts are tight, the alignment of both rods should allow easy assembly and disassembly of the coupling. If any binding, loosen and retighten all the rod locknuts to improve the alignment. Misalignment causes premature wear of seal and packings.

7. Tighten the packing nut until there is resistance, then 1 full turn tighter. Approximately 4 threads will show when new packings are installed. Fill the wet cup of the packing nut 1/3 full with TSO.
8. Start the pump and operate it slowly (at low engine speed) to check the piston rod for binding. Adjust tie rod lock nuts if necessary to eliminate binding.
9. Run unit at maximum pressure for several minutes, then relieve pressure and repeat step 7.

SERVICING UPPER & LOWER CHECK VALVES

LOWER CHECK VALVE (SEE FIG. 9 & 11)

1. Screw the lower check valve nut (187-018) out of the pump housing (187-313) containing intake seat support (187-017).
2. Remove the intake seat (187-065), O-Ring (187-034), intake ball (187-020) and retainer (187-016).
3. Clean all parts and inspect them for wear or damage, replacing parts as needed. Old O-Rings should be replaced with new ones.

Note: O-Ring PN 187-028 is available in the following materials: Viton for water base paint - letter "V" after part no. Teflon for other fluids - letter "T" after part no.

4. Clean inside of pump housing (187-313).
5. Reassemble the valve and screw it onto the pump housing if no further pump service is needed.

PISTON ROD, UPPER CHECK VALVE (SEE FIGURE 11)

1. Stop piston rod in middle of it's stroke. Remove retaining rings (189-048).
2. Slip the sleeve (189-047) off the coupling halves (189-046) and remove both coupling halves. This will disconnect piston rod from pump drive.
3. Screw the lower check valve nut (187-018) off the pump and remove lower check valve.
4. Disconnect the fluid hose.
5. Loosen the packing nut and push the piston rod down and out of the housing.
6. Place rod holder Part No. 187-248 in a vise. Slide the rod into the holder and lock in place with a 1/4" pin. Push the pin through the holder and the rod. Using a 7/16" allen wrench, screw the seat support (187-021) out of rod, remove O-Ring (187-033T), seat (187-044) and ball (115-022) out of the piston rod (187-311).

NOTE: Retainer (187-032) with O-Ring (187-033V) and ball stop (187-022) may remain in the piston rod. Clean and check visually the ball stop (187-022) for excessive wear. If ball stop needs to be replaced, install any screw with thread 1/2-13NC into the threaded hole of retainer (187-032) and pull straight out.

7. Clean all parts and inspect them carefully for wear or damage. Inspect the outside of the piston rod for scoring or wear. Replace these parts if needed. A worn piston rod will cause premature wear of packings.
8. Install parts back into piston rod as per Fig. 11, page 21 VIEW A as shown.

Note: Before installing discharge seat support (187-021), place two drops of loctite No. 242 (blue) on threads before assembling.

9. After installation and tightening of discharge seat support, check to ensure ball stop (PN 187-022) is properly installed in piston rod and has not fallen into piston bore. Check by pushing on the ball and feeling a positive stop against the ball stop.

FIGURE 9

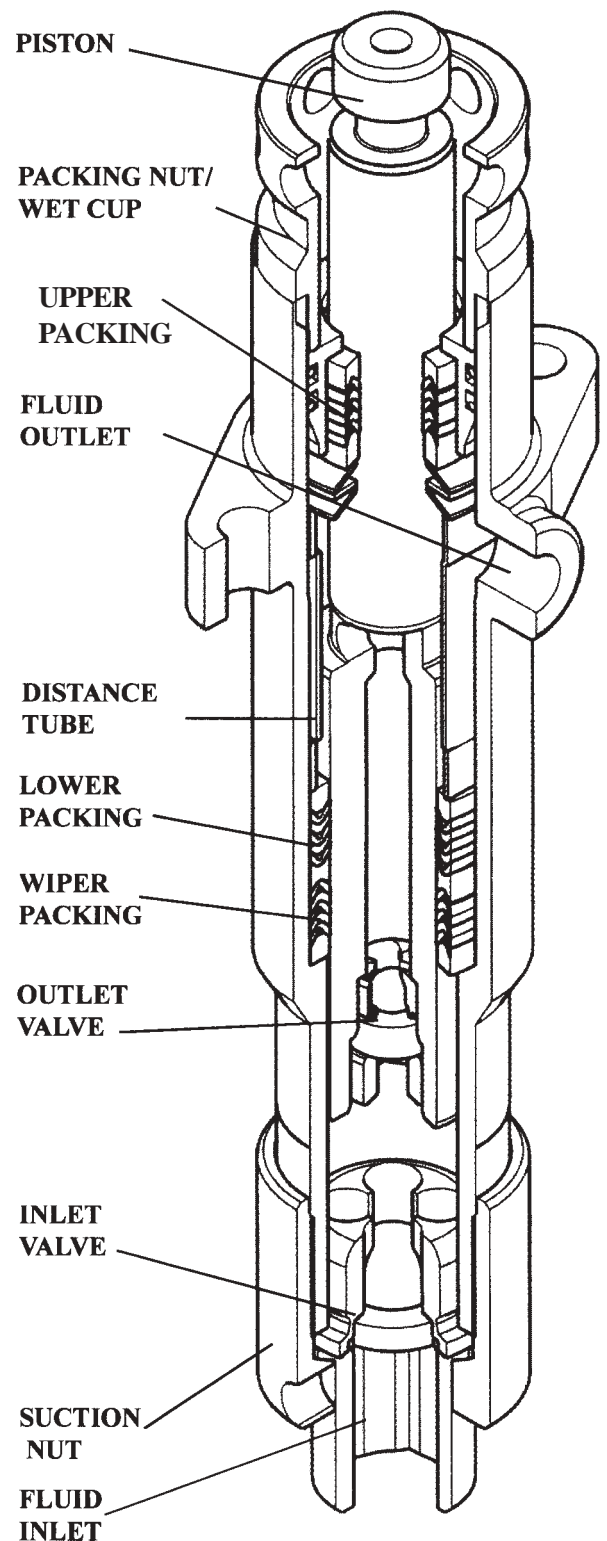

V-PACKING REPLACEMENT

V-PACKING REPLACEMENT KIT SEVERE DUTY- PART NO. 187-040

Contains: Leather & Plastic Packings, Teflon & Viton O-Rings, Balls & Upper Ball Stop & plastic dual sided female adaptor & Large Plastic Male Glands.

GLAND KIT - PN 187-064

V-PACKING REPLACEMENT INSTRUCTIONS

FIGURE 10

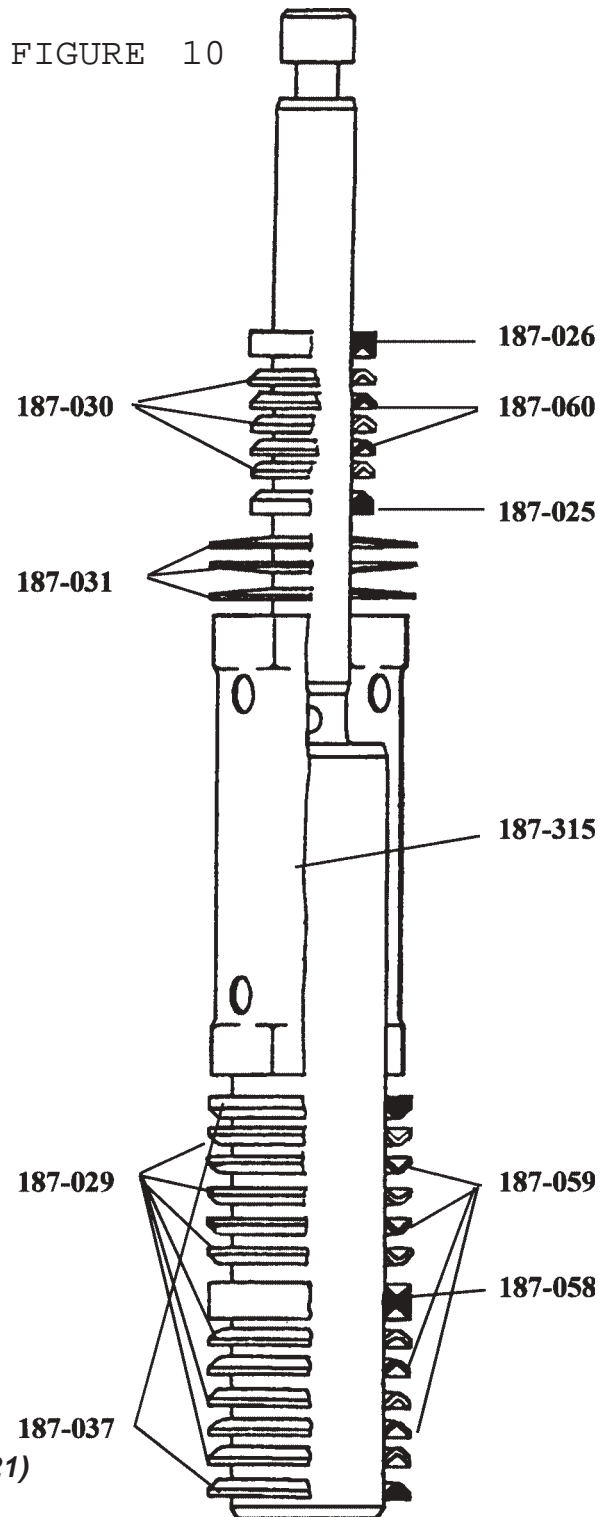

1. Remove the fluid pump as per the "Fluid Pump Disconnect" instructions page 15.
2. Unscrew and remove the lower check valve per instructions page 16.
3. Unscrew & remove the packing nut (187-046). Push the piston rod down through the packings and out of the pump. Wrap some masking tape around the bottom of the piston. Now push the piston back through the pump and remove through the top. The packings and glands will be removed with the piston rod, leaving the pump body (187-313) empty. Utilizing tool (PN 187-249) the complete packing set can be removed quickly and easily.
4. Disassemble and clean all parts for reassembly. Discard old packings and lower glands. Save upper glands (187-026 & 187-025) for reuse.
5. Hold piston rod in a vise, using the special block (PN 187-248) and pin (PN 187-250) tools.
6. Use a 7/16" allen wrench to remove the discharge seat support (PN 187-021) from the piston rod.
7. Pull out the discharge seat, gasket and upper ball from the piston rod.
8. Screw in a 3/8" bolt into the discharge retainer and extract the retainer with O-Ring attached. The discharge ball stop will fall out of the piston rod once the retainer is removed.
9. Clean all parts, replace O-Rings and ball stop and reassemble as per drawing above.

Note: Before installing discharge seat support (187-021) place two drops of loctite (blue) No. 242 on threads before assembling.

10. After installation & tightening of discharge seat support, check to ensure ball stop (PN 187-022) is properly installed in piston & has not fallen into the piston bore. Check by pushing on the ball & feeling a positive stop against the ball stop (PN 187-022).

CONTINUED ON NEXT PAGE.....

FLUID PUMP - 187-410

FIGURE 11

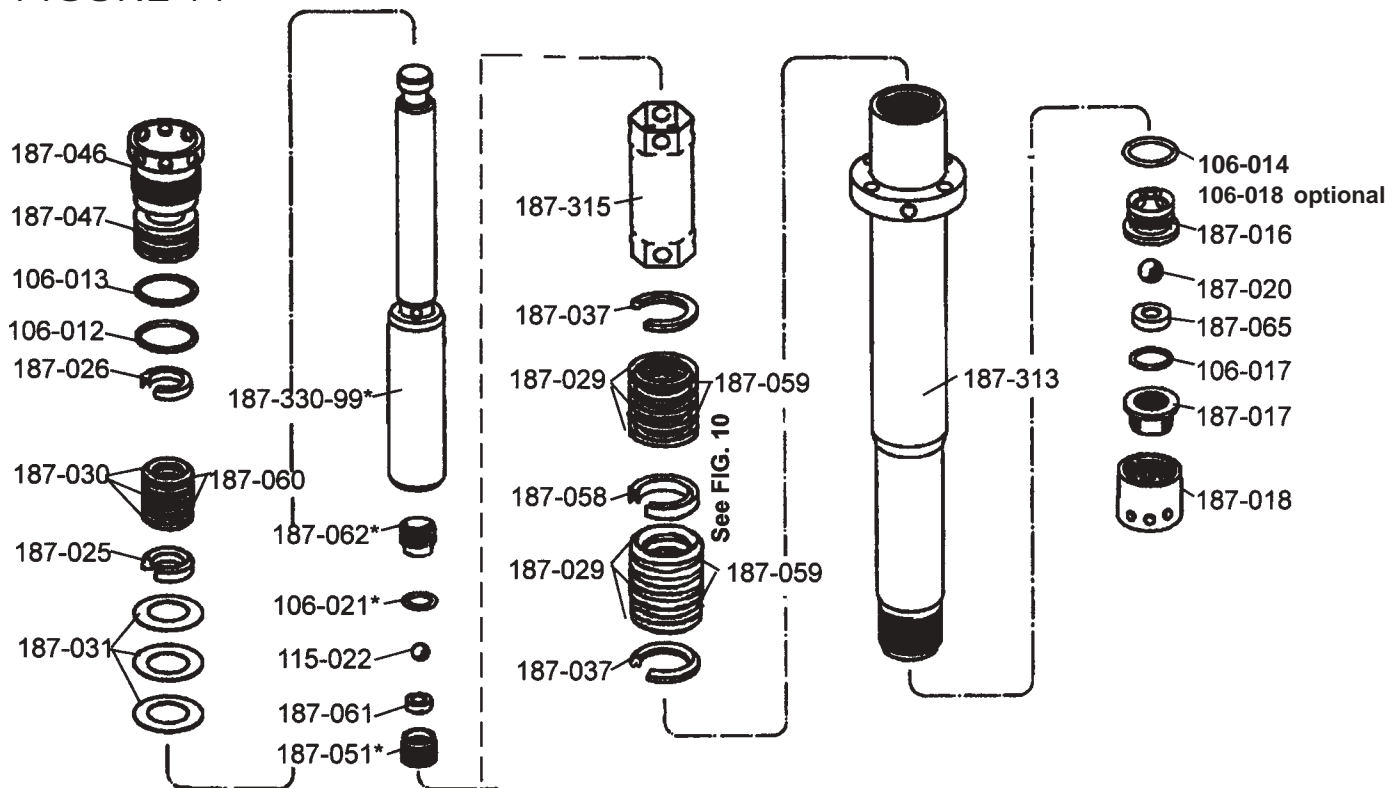

* INCLUDED WITH 187-330-99 PISTON ASSEMBLY

REASSEMBLY

11. Lubricate leather packing in lightweight oil for 10 minutes prior to assembly.
12. Remove masking tape from piston (if used).
13. Reassemble all parts onto piston in the following order (Per Fig. 10):
 - a. Start with lower metal male gland (187-037).
 - b. Five V-Packings (187-029 & 187-059) Inverted "Λ".
 - c. Female adaptor (187-058).
 - d. Five V-Packings (187-029 & 187-059) "V" up.
 - e. Upper Male gland (187-037).
 - f. Slide on distance tube (187-315).
 - g. Three Belleville Springs (187-031) starting with the first spring facing down (∩) and next facing up (∪) and the third facing down (∩).
 - h. Slide on upper male gland (187-025) with bevel facing up.
 - i. Five V-Packings (187-030 & 187-060) Inverted "Λ".
 - j. Female Gland (187-026).
 - k. Slide on the V-Packing holder (187-047) with O-Rings (187-027V & 187-027T) in place over upper packings.
14. Lubricate inside of cylinder & outside of packings, then slide complete assembly into the fluid body (187-313). Thread packing nut (187-046) into cylinder & tighten handtight.
15. Install the lower check valve and tighten the lower check valve nut (187-018).
16. Connect the pump to the machine as per fluid pump reinstall procedure on page 15.
17. Tighten the packing nut (clockwise) until resistance is felt against the belleville springs. **Now turn it one (1) turn clockwise.** Run unit to maximum pressure for 5 minutes, relieve pressure and repeat packing nut adjustment.

BALL VALVE - PART NO. 100-119

FIGURE 12

PARTS LIST - FIGURE 12		
ITEM NO.	PART NO.	DESCRIPTION
1	100-162	Handle
2	100-163	Screw
3	100-164	Ball
*	KIT-119	Repair Kit

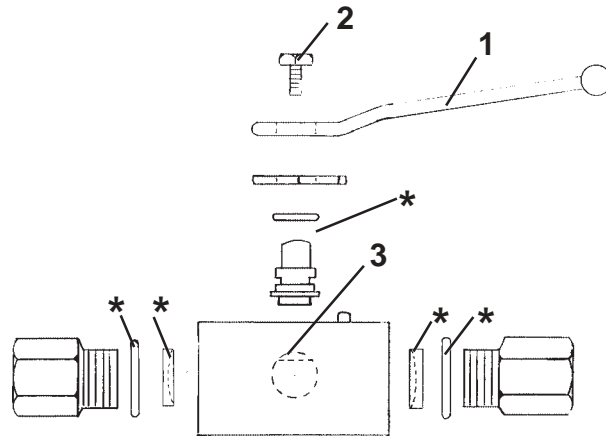

TROUBLESHOOTING - CLUTCH DOES NOT ENGAGE

- STEP 1:** Ensure that the pressure control knob (POT) is in the maximum (CW) position.
- STEP 2:** Remove the upper and lower clutch and electrical covers.
- STEP 3:** Check all electrical connections between the engine magneto, sensor, control board and clutch for loose connections or damaged leads. See Fig. 13.
- STEP 4:** Disconnect the two leads from the control board (blue) and the clutch assembly (black). Using a multi-meter, with the engine at maximum RPM, pressure control knob in the maximum position and the prime valve in the open (priming) position, test the DC voltage from the boards leads. This voltage must be 13-14 VDC. If the readings are correct, the board, sensor and magneto are okay and the problem is in the clutch assembly. If this is the case, proceed to Step 5. If the voltage is outside this range go to Step 7.
- STEP 5:** Measure resistance between the clutch leads (blue or black). This value must be 10-16 ohms. If this reading is out of specifications the clutch is defective and must be replaced, otherwise continue troubleshooting.
- STEP 6:** If the clutch resistance readings of Step 5 are correct, check the spacing between the clutch field and plate. The gap should be .012" to .024". If the gap is greater than .028" the gap is too wide. If this gap is too wide, remove spacer (Fig. 15 Item 4) from the clutch assembly. Should the clutch still not engage, replace the clutch assembly. See page 21 in manual.
- STEP 7:** When the DC voltage from the board is not 13-14 VDC, disconnect the control board lead (black) from the engine magneto lead (pink), located on the side of the engine. With the engine at maximum RPM, pressure control knob in maximum (CW) position and prime valve open (priming), read the AC voltage from the magneto lead to the sprayer frame. This reading should be 19-24 VAC. If outside this range, contact your local Honda repair facility for magneto replacement. If the magneto is producing the proper AC voltage, continue to Step 8.
- STEP 8:** Test the sensor by reading the resistance between the red and black wires. The resistance runs between 1.8- 3.5 kohms. A defective sensor usually shows no resistance (open). If the reading is outside standards, replace the sensor. An alternative method to test the sensor, is to plug a new sensor into the board and see if the clutch will engage.
- STEP 9:** When Steps 7 & 8 have been completed and the magneto and sensor check good, the electrical control board is the only item left, replace the board. See page 20.

⚠ CAUTION

When using this method, turn the machine off as soon as the clutch engages. This is important because the sensor plugged into the board is not measuring pressure in the fluid section. The machine can build extreme pressure if not immediately turned off.

REPLACEMENT OF ELECTRICAL CONTROL BOARD

1. Remove electrical cover.
2. Disconnect sensor lead from Electrical Board.
3. Disconnect two clutch leads on Electrical Board from leads on clutch.
4. Disconnect the Electrical Board green "ground" lead from frame, if so equipped.
5. Using a 1/16" allen wrench, loosen set screw in Pressure Control Knob and remove knob.
6. Using a 1/2" nut driver or 1/2" deep socket, remove nut from pressure control shaft. This will allow removal of electrical control board from frame.
7. Replace Electrical Board Assembly in reverse order. Adjust pressure as per procedure below, "Pressure Calibration on the Electrical Control Board".

PRESSURE CALIBRATION ON THE ELECTRICAL CONTROL BOARD

1. Turn "Pressure Calibration" Trimpot adjustment on electrical control board in the counter clockwise direction at least 15 revolutions.
2. Connect 5000 psi glycerine pressure gauge on output of pump between hose and gun to monitor fluid pump pressure.
3. Start engine and run at maximum RPM. Turn Prime/Pressure Relief Valve to the open (prime) position. Turn Pressure Control Knob to maximum position (fully clockwise).
4. Using an insulated screwdriver, adjust "Pressure Calibration" Trimpot by turning clockwise until the clutch engages. When the clutch engages the pump will commence priming. When pump is primed, turn the Prime/Pressure Relief Valve to the closed (pressure) position.
5. Trigger gun. The pressure should drop approximately 350-400 psi. The clutch will engage and build pressure to 3000 psi and disengage. Trigger gun several times to ensure proper pressure setting. Pressure drop is a function of hose size. It will be 350-450 psi with 50 ft. of 3/8" hose, but it will be larger if only 50' of 1/4" hose is used.
6. Turn Pressure Control Knob to minimum position. The clutch should disengage and pump will stop moving.
7. Secure leads with tie strap.
8. Replace cover on unit. Ensure the leads are not pinched or damaged in the process of replacing covers.

The pump will begin to pressurize and the clutch will disengage at a low pressure. Continue turning the Trimpot clockwise to increase pressure to 3000 psi.

FIGURE 13

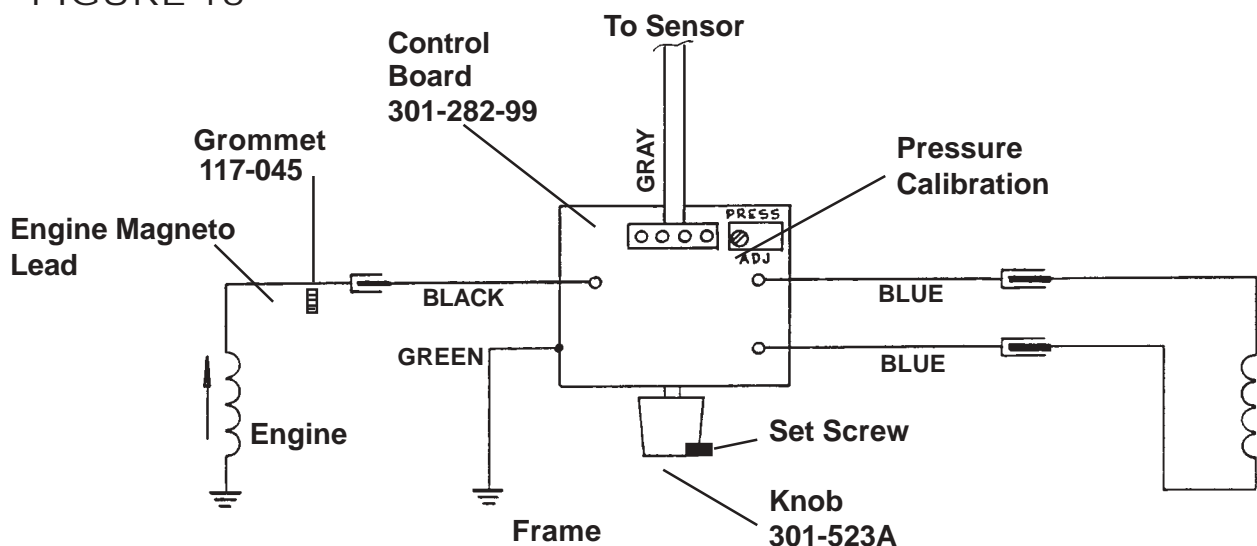

CLUTCH REPLACEMENT

REMOVE CLUTCH AS FOLLOWS:

1. Remove the upper and lower clutch covers.
2. Extract the splash cover from the clutch brackets and spacer tubes.
3. Disconnect the two clutch leads from the electrical control board leads.
4. Unscrew the whip hose from the manifold filter.
5. Remove the two nuts on the fluid section bracket and shock mounts.
6. Remove the four nuts from the gearbox (Fig. 27, Item 23) which pass through spacer tubes (Fig. 27, Item 15).
7. Pull the cog belt loose off the engine shaft cog pulley (Fig. 14, Item 2) and remove the gearbox/clutch assembly from the rest of the unit.
8. Place gearbox in vice by gripping the flat part of the drive crank allowing the clutch assembly to face up. Use caution and not allow gearbox to swing and damage casting against vice.
9. Hold coupling screw, with 13/16" wrench, then with 5/16" allen wrench, screw differential screw (Fig. 15, Item 1), out of coupling screw and gearbox shaft.
10. Screw large end of differential screw into coupling nut assembly (Fig. 15, Item 2) and pull out of clutch assembly.
11. The clutch (Fig. 15, Item 5) can now be removed. Fig. 15, Items 3-8 should be inspected for wear and replaced if needed.

INSTALL NEW CLUTCH AS FOLLOWS:

1. With gearbox held as described above (Step 8), place first spacer (Fig. 15, Item 8) and bearing (Fig. 15, Item 6) onto gearbox shaft.
2. Insert snap rings (2), (Item 7) into recesses of cog pulley portion of clutch. Place cog pulley portion of clutch with cog belt attached onto shaft.
3. Place second spacer, (Item 8) into cog pulley portion of clutch. This spacer will rest on the first bearing (Item 6) installed.
4. Insert second bearing (Item 6), on top of upper snap ring (Item 7).
5. Lay removable spacer (Item 4) on top of last bearing. If the clutch air gap is larger than .028, do not use removable spacer. Put spacer (Item 3) over removable spacer, (if used) and top bearing.
6. Place coil portion of clutch down onto cog pulley portion of clutch and center on gearbox shaft.
7. Screw differential screw (Item 1) into coupling screw and nut, until 1/16" is showing. (See Fig. 16)
8. Push coupling nut assembly (Item 9) into clutch assembly until it comes to a positive stop. (Differential screw comes into contact with the threaded gearbox shaft.)

INSTALL NEW CLUTCH CONTINUED.....

9. With 13/16" wrench on coupling screw and 5/16" allen wrench in differential screw, simultaneously screw coupling nut assembly into gearbox shaft by turning clockwise until a positive stop is reached.
10. Hold coupling nut ass'y and tighten differential screw to 30 ft.-lbs. This will expand the coupling assembly, thereby holding the clutch assembly to gearbox shaft. Turn clutch observing clutch gap. The pulley should turn freely with a gap of .012" to .024" between the two clutch faces. If the gap is greater than .028" remove spacer. Reassemble and check gap for proper clearance.
11. Reinstall the gearbox/clutch assembly, by placing the fluid section bracket over the shock mount bolts.
12. Slip cog belt over the engine shaft cog pulley.
13. Re-assemble four studs, spacer tubes and nuts as before. Slightly loosen four screws (Fig. 14, Item 5).
14. Tighten set screws (Fig. 14, Item 6) until cog belt is properly tensioned, then tighten the four screws (Item 5).
15. Tighten the shock mount nuts.
16. Reattach the whip hose to the manifold filter.
17. Connect the clutch and board leads.
18. Replace the splash shield.
19. Test the clutch for proper operation.
20. Replace clutch covers.

FIGURE 14

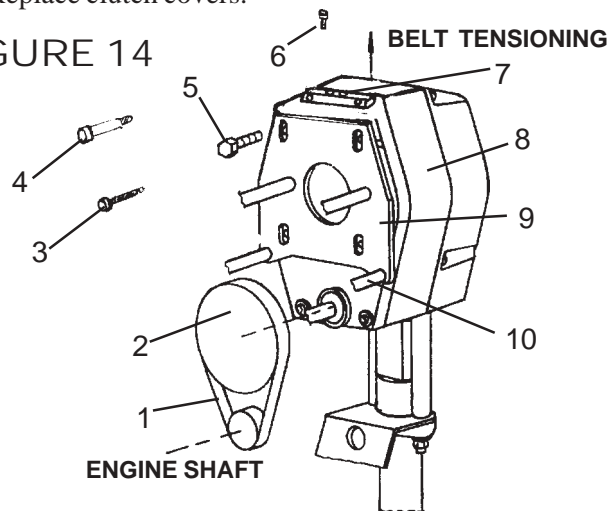
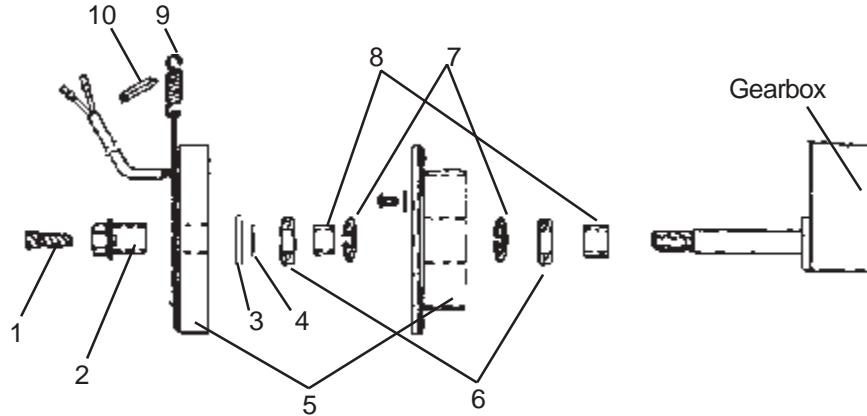

FIGURE 14 PARTS LIST

ITEM NO.	PART NO.	DESCRIPTION
1	301-231	Cog Belt
2	301-264	Clutch Replacement
3	305-088	Screw
4	100-175	Shoulder Screw
5	100-173	Screw Flanged (4)
6	100-174	Set Screw (2)
7	301-534	Block Tensioner
8	301-207-99	Gearbox
9	305-045	Plate
10	305-046	Spacer Tube (4)

CLUTCH ASSEMBLY

FIGURE 15



Item No.	Part No.	Description	Item No.	Part No.	Description
1	112-041	Screw-Differential	6	301-037	Bearing (2)
2	112-054	Coupling Nut Assy	7	100-333	Retaining Ring (2)
3	301-412	Spacer	8	301-274	Spacer (2)
4	301-413	Spacer-Removable	9	136-068	Spring
5	301-264	Clutch-Replacement	10	301-316	Rubber Edge

FIGURE 16

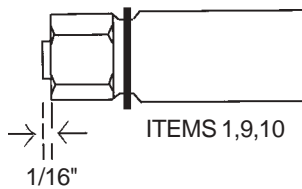

PARTS LIST FIGURE 17

FIGURE 17

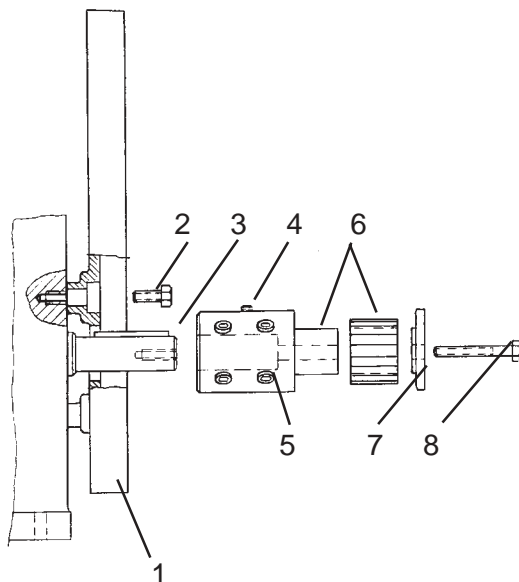
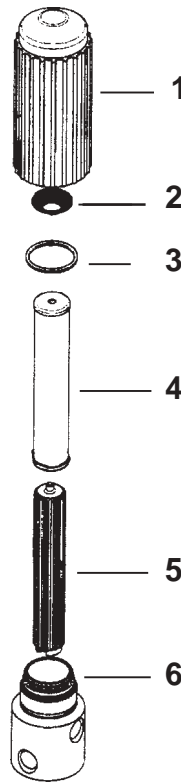

FIGURE 17 PARTS LIST		
ITEM NO.	PART NO.	DESCRIPTION
1	305-012	Adaptor
2	100-392	Screw (4)
3	112-029	Key
4	100-357	Screw
5	100-383	Screw (4)
6	301-222A	Sheave
7	301-229	Thrust Plate
8	301-230	Screw

MANIFOLD FILTER

FIGURE 18

FIGURE 18 PARTS LIST		
ITEM	PART NO.	DESCRIPTION
1	111-202	Base*
2	301-356	Spring*
3	106-007	O-Ring*
4	111-204	Filter
5	111-203	Support*
6	111-201	Base*



SUCTION ASSEMBLY PN 301-090-99

FIGURE 19

FIGURE 19 PARTS LIST		
ITEM NO.	PART NO.	DESCRIPTION
*	301-517	Suction Hose Ass'y (includes items 1-5)
1	141-008	Inlet Strainer
2	301-514	Suction Tube
3	301-516	Hose Clamps (2)
4	301-513A	Hose
5	100-165	Elbow
6	188-377	Return Pipe
7	100-128	Elbow
8	100-012	Whip
9	100-126	Elbow **
10	100-385	Reducer**

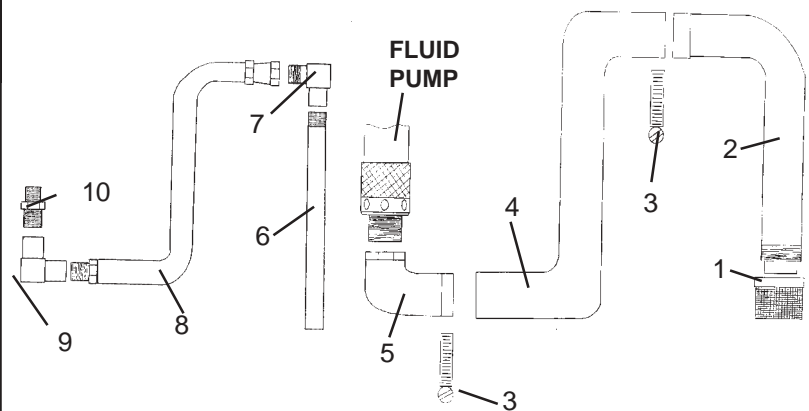

** Used on units equipped with either the 100-180 or 331-050 prime valves. The 301-090 suction ass'y also includes the 100-081A Elbow for units with the 138-001 marathon prime valve.

SURE STRIPE 6000

FIGURE 20

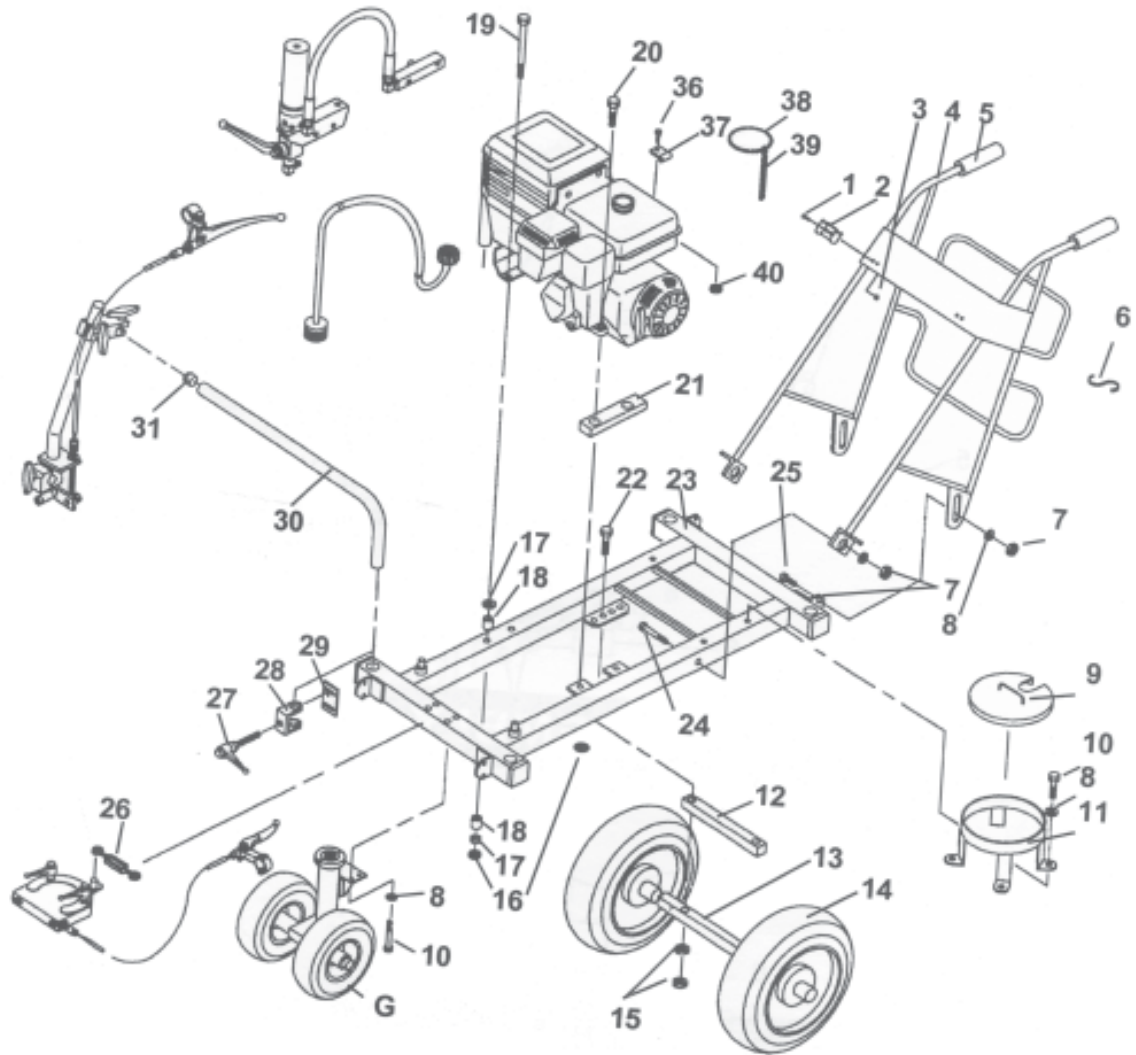

ITEM NO.	PART NO.	DESCRIPTION	ITEM NO.	PART NO.	DESCRIPTION
1	331-342*	Screw (2)	19	173-005	Screw (2)
2	331-138*	Clamp- Cable	20	136-123	Screw (2)
3	120-021*	Lock Nut (2)	21	301-535	Rubber Pad
4	305-057*	Handle Weldment	22	100-321	Screw (2)
5	305-058*	Rubber Grip (2)	23	305-195	Frame
6	331-135*	Spring Clip	24	100-172	Screw (2)
7	113-022	Nut (6)	25	111-044	Screw (2)
8	140-029	Washer (12)	26	136-163	Turnbuckle
9	301-533	Bucket Lid	27	305-044	Adjustable Handle
10	111-044	Screw (8)	28	305-051 M	Clamp
11	305-144	Bucket Holder	29	305-108	Plate
12	305-163	Spacer Bar	30	305-076	Arm
13	305-052	Axle	31	143-027	Ball guide
14	305-056	Wheel (2)	36	136-123	Screw
15	140-051	Nut (4)	37	136-197	Terminal Ring
16	100-317	Nut (2)	38	136-133	King Ring
17	100-344	Washer (4)	39	136-131	Chain Sash
18	301-536	Shock Mount (4)	40	100-317	Nut

FIRST GUN ASSEMBLY - PN 305-167-99

FIGURE 21

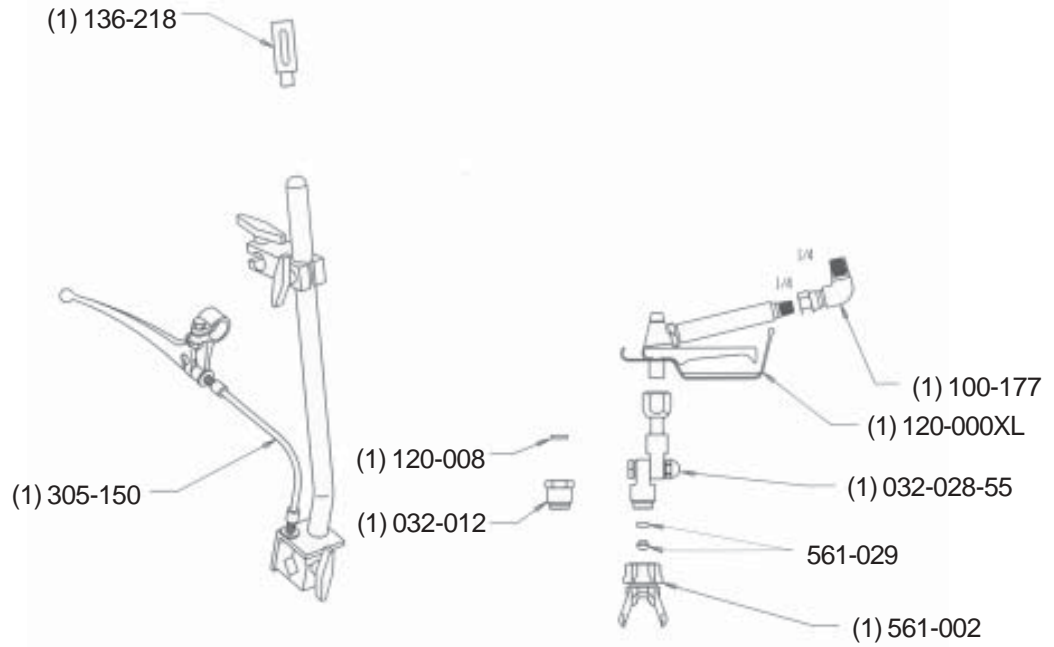

PART #	DESCRIPTION	PART #	DESCRIPTION
032-012	Gun Adapter	136-218	Cable Guide
032-028-55	Swivel Assembly	305-150	Gun Holder Assembly
100-177	90 Degree 1/4"	561-002	Tip Guard
120-000XL	Basic 007 gun	561-029	Seal Kit for Tip Guard
120-008	Tip Washer		

SECOND GUN ASSEMBLY - PN 305-176-99

FIGURE 22

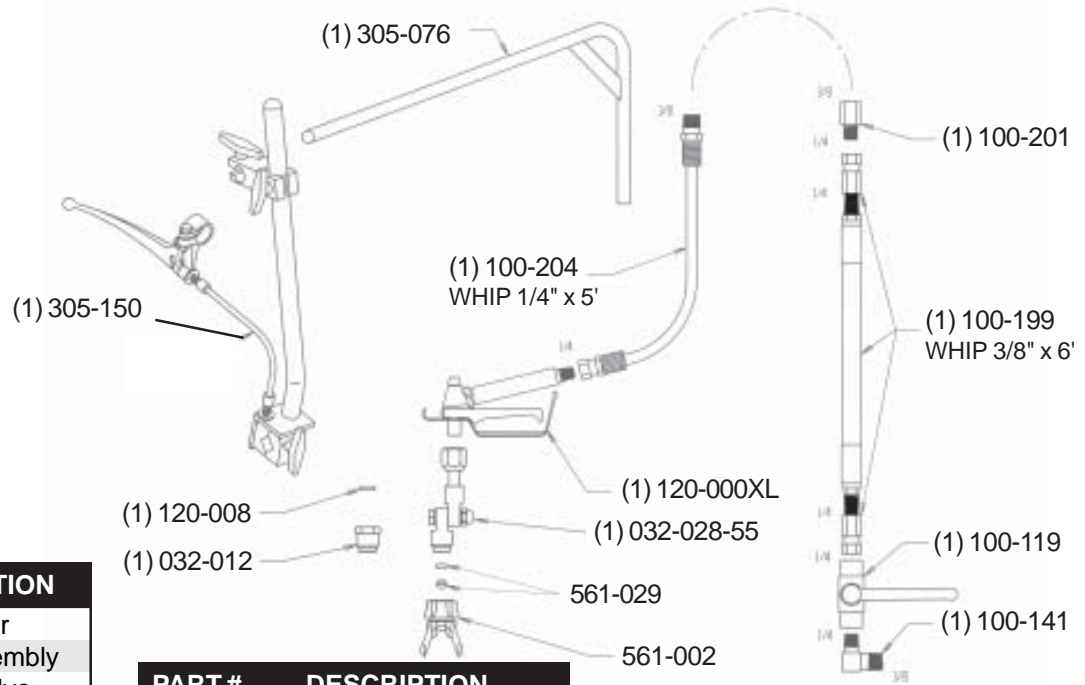

PART #	DESCRIPTION
032-012	Gun Adapter
032-028-55	Swivel Assembly
100-119	1/4" Ball Valve
100-141	1/4 - 3/8 Elbow
100-199	3/8 X 6' Whip Hose
100-201	3/8 - 1/4 Adapter
100-204	1/4 X 5' Whip Hose

PART #	DESCRIPTION
120-000XL	Basic 007 Gun
120-008	Tip Washer
305-076	Arm for gun Assembly
305-150	Gun Holder Assembly
561-002	Tip Guard
561-029	Seal Kit for Tip Guard

6000 BRAKE ASSEMBLY PN 305-180

FIGURE 23

ITEM	PART NO.	DESCRIPTION
1	139-351	Roll Pin
2	305-184	Cam
3	305-183	Shaft
4	305-182	Bushing
5	140-034	Washer
6	140-051	Nut
7	305-044	Handle
8	305-108	Plate
9	305-181	Clamp
10	140-051	Nut
11	188-125	Screw

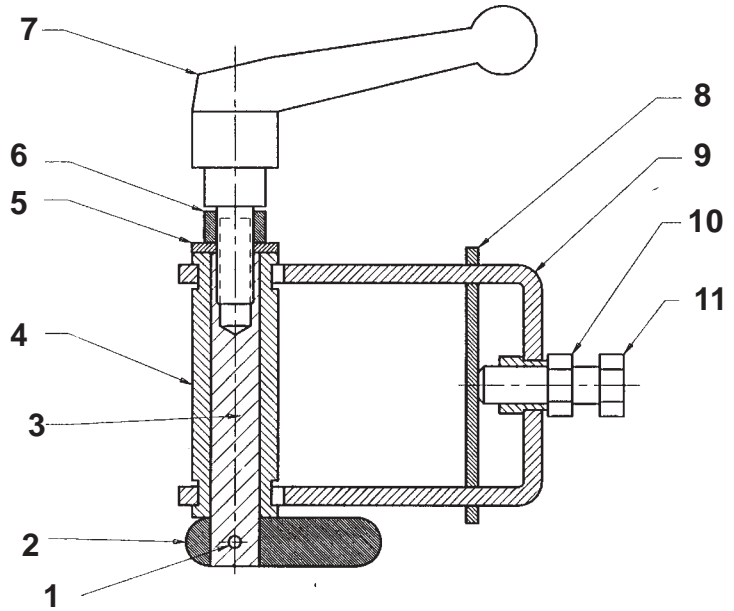

GUN HOLDER ASSEMBLY(305 - 150)

FIGURE 24

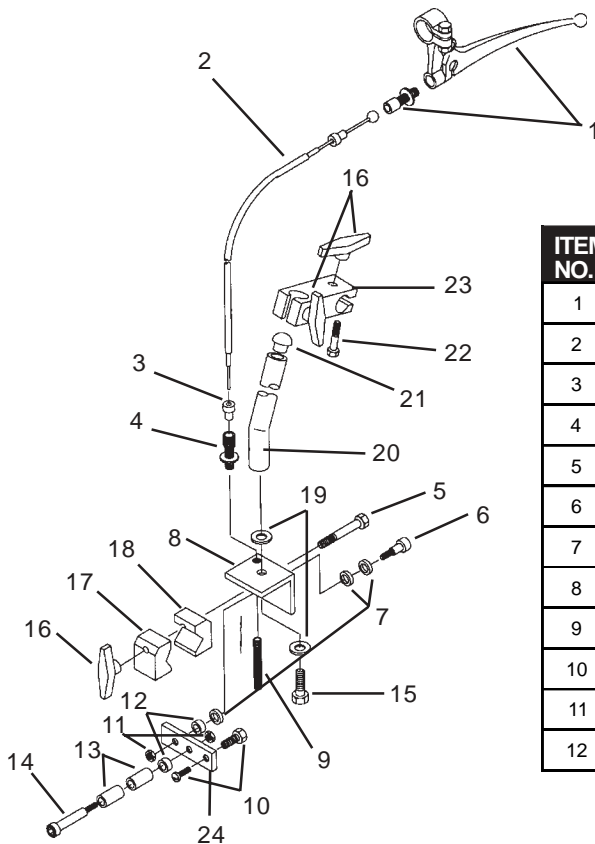

ITEM NO.	PART NO.	DESCRIPTION	ITEM NO.	PART NO.	DESCRIPTION
1	305-142	Lever Assembly	13	305-159	Sleeve Bearing (2)
2	305-077-99	Cable Assembly - Gun	14	100-342	Shoulder Screw
3	305-089	Cable Insert	15	169-050	Screw
4	305-141	Cable Adjuster	16	305-157	Knob (3)
5	100-321	Screw	17	305-152	Clamp - outer
6	305-158	Shoulder Screw	18	305-151	Clamp - inner
7	305-156	Thrust Washer (2)	19	113-027	Lock Washer (2)
8	305-154	Bracket	20	305-153	Tube - Gun Holder
9	116-100	Spring	21	143-027	Ball Glide
10	305-079	Wire Swivel Assembly	22	188-125	Screw (2)
11	140-045	Jam Nut (2)	23	136-019P	Swivel Clamp Assembly
12	305-161	Spacer (2)	24	305-155	Lever

LOCK ASSEMBLY SURE STRIPE 6000 (305-030)

FIGURE 25

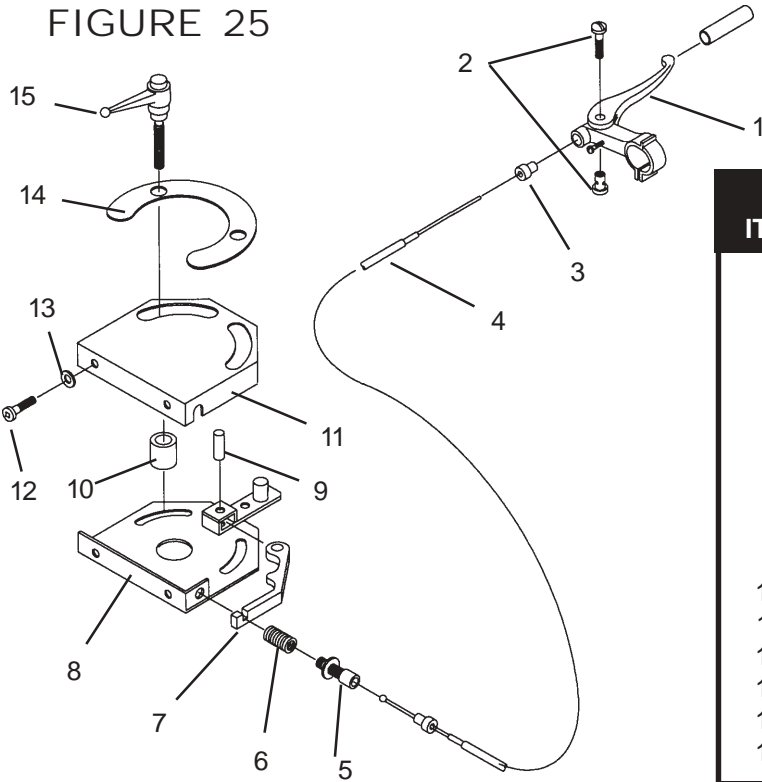

FIGURE 25 PARTS LIST

ITEM NO.	PART NO.	DESCRIPTION
1	305-105	Lever
2	136-023	Cable End Lug
3	305-089	Cable Insert
4	305-092-99	Cable Ass'y - Caster
5	305-141	Cable Adjuster
6	305-032	Spring
7	305-081	Lever
8	305-031	Base Lock Weldment
9	305-050	Dowel Pin
10	305-027	Spacer (2)
11	305-049	Cover - Lock
12	305-093	Screw (3)
13	305-094	Washer (3)
14	305-091	Seal
15	305-020	Adjustable Handle (2)

SWIVEL ASSEMBLY - SURE STRIPE 6000 (PART NO. 305 - 022)

FIGURE 26

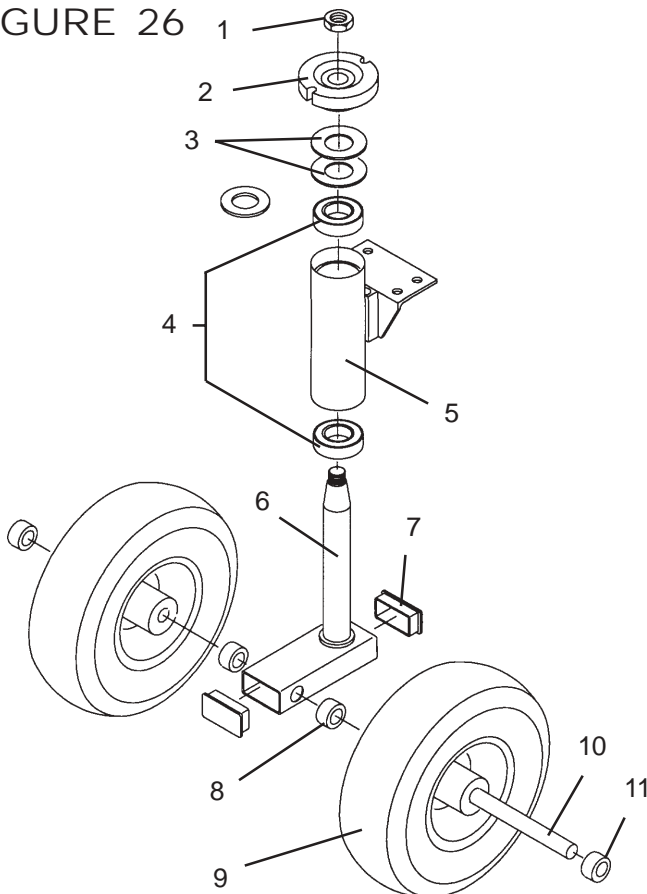
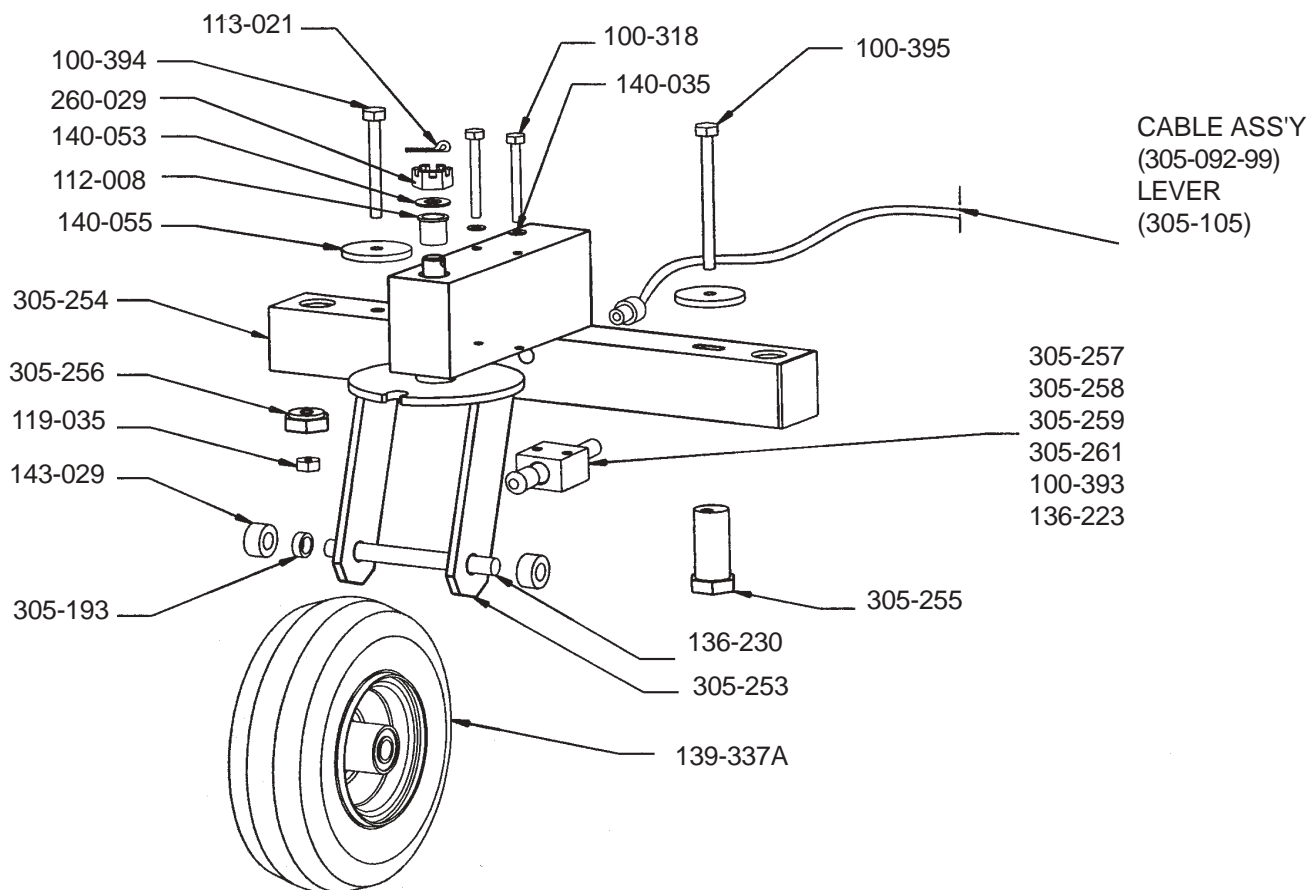

FIGURE 26 PARTS LIST

ITEM NO.	PART NO.	DESCRIPTION
1	301-227	Jam Nut
2	305-025	Swivel Lock
3	305-028	Belleville Spring (2)
4	301-036	Bearing (2)
5	305-023	Swivel Body
6	305-024	King Pin
7	305-037	Plug (2)
8	305-039	Spacer (2)
9	139-337A	Wheel (2)
10	305-038	Axle
11	143-029	Set Collar

SWIVEL WHEEL ASSEMBLY - SURE STRIPE 4500 - P.N. 305-260

FIGURE 27



PART #	DESCRIPTION	PART #	DESCRIPTION	PART #	DESCRIPTION
100-318	Screw 5/16-18 x 3.75L	139-337A	Wheel	305-253	Swivel Clamp
100-393	Screw 6-32 x 2.0L	140-035	Washer .670 x .370	305-254	Swivel Frame
100-394	Cap Screw 3/8- 16 x 2.75L	140-053	Washer M18 x 3.0	305-255	Adjustment Sleeve
100-395	Cap Screw 3/8- 16 x 5.0L	140-055	Washer .375 x 2.0	305-256	Pivot Washer
112-008	Flanged Bearing	143-029	Set Collar	305-257	Swivel Lock Pin
113-021	Cotter Pin	260-029	Castle Nut	305-258	Swivel Lock
119-035	Nut 3/8 -16	305-092-99	Cable Assembly	305-259	End Lug
136-223	Spring	305-105	Lever	305-261	Cable Holder
136-230	Axle 5/8 x 5.50L	305-193	Spacer		

POWER UNIT ASSEMBLY

FIGURE 28

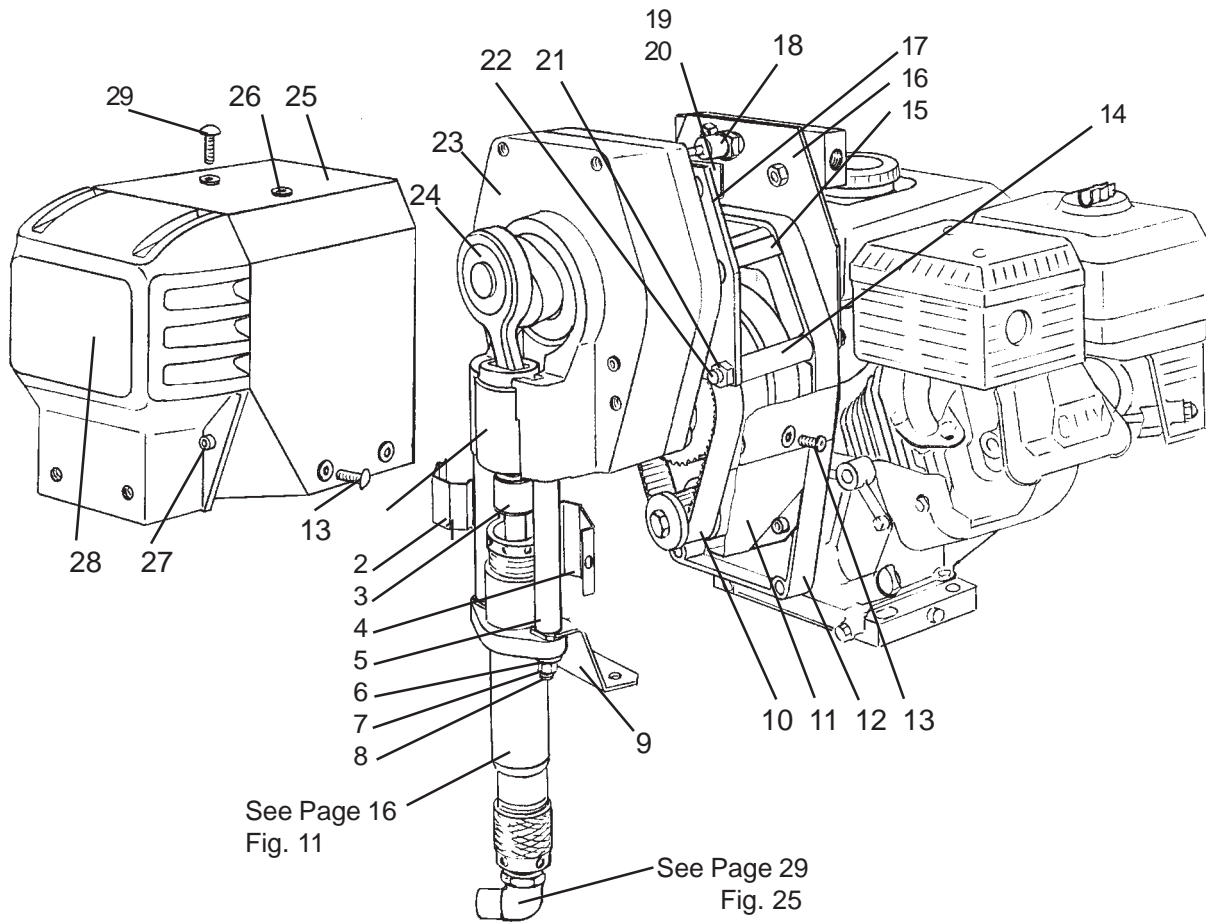
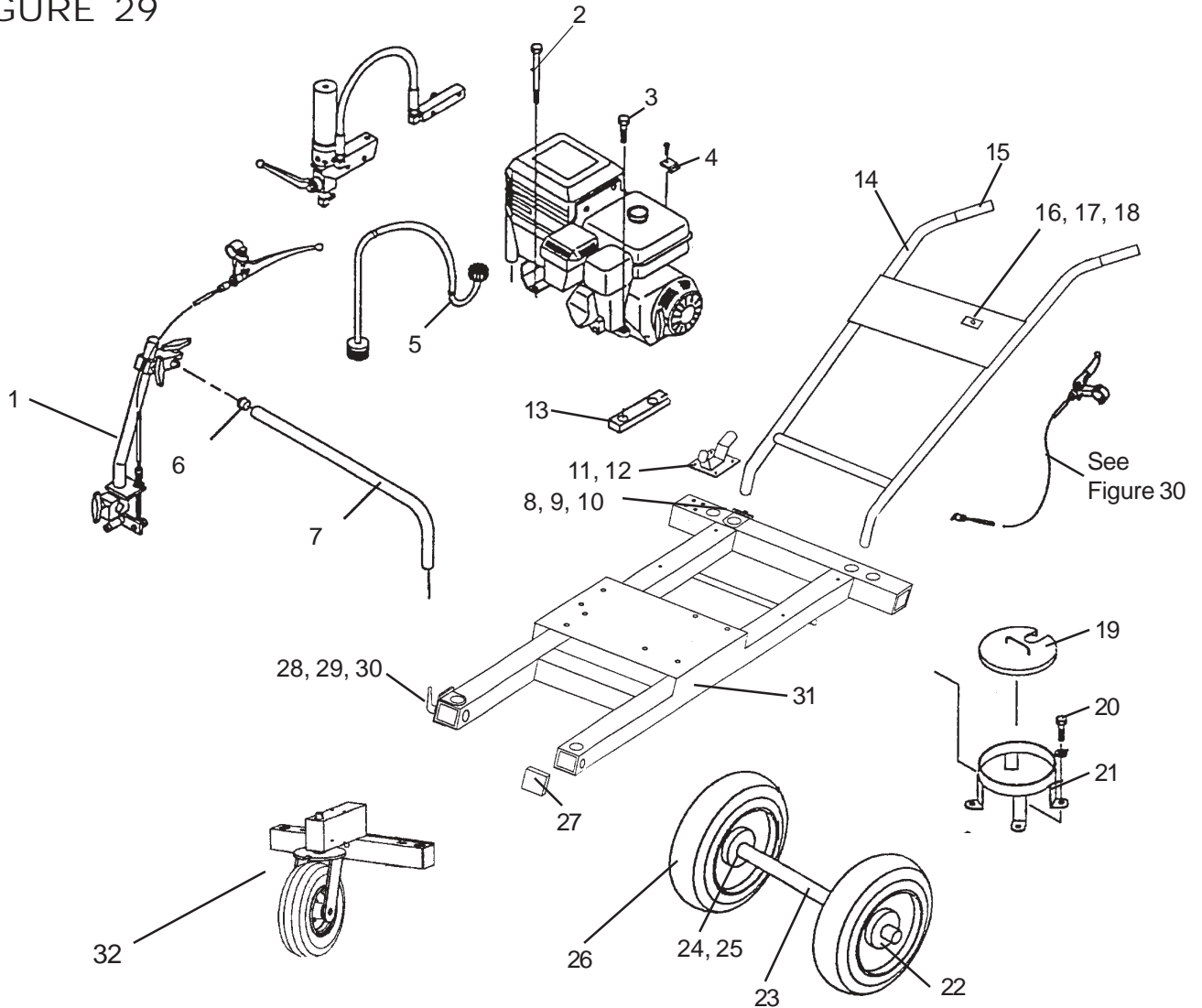

FIGURE 28 PARTS LIST

Item No.	Part No.	Description	Item No.	Part No.	Description
1	301-047	Sleeve Bearing	17	305-045	Plate - Gearbox Mount
2	301-189	Shield Front	18	331-294-99	Sensor Ass'y
3	189-046A	Coupling Set Ass'y	19	301-282-99	Pressure Control
4	301-092	Shield - Rear	20	301-523A	Knob Ass'y
5	301-048	Spacer - Tube (2)	21	140-044	Nut (8)
6	140-035	Washer, Lock (2)	22	305-047	Screw (4)
7	140-051	Nut (2)	23	301-207-99	Gearbox 3/4" (model 4500)
8	100-328	Stud (2)		301-208-99	Gearbox 1" (model 6000)
9	305-013	Holder	24	301-291	Connecting Rod Ass'y
10	301-231	Cog Belt	25	305-066	Cover Top
11	305-067	Cover-Bottom	26	301-135	Grommet (6)
12	305-012	Adaptor	27	100-312	Screw (4)
13	100-339	Screw (4)	28	301-022	Cover -Gearbox
14	305-046	Spacer Tube (4)	29	301-337	Screw (2)
15	301-529	Cover			
16	305-064	Holder-Manifold			

SURE STRIPE 4500

FIGURE 29



ITEM NO.	PART NO.	DESCRIPTION	ITEM NO.	PART NO.	DESCRIPTION
1	305-150	Gun Holder Ass'y	19	301-533	Lid
2	173-005	Screw (2)	20	119-026	Screw (4)
3	136-123	Screw (3)	21	305-144	Bucket Holder
4	136-197	Terminal Ring	22	143-029	Set Collar (2)
5	301-517	Suction Hose Ass'y	23	301-170	Axle
6	143-027	Ball Guide	24	112-058	Flanged Bearing (2)
7	139-353	Arm	25	100-369	Wave Washer (2)
8	305-108	Plate (2)	26	301-165	Wheel (2)
9	305-051M	Clamp (2)	27	100-621	Cap (4)
10	100-370	Screw (2)	28	305-108	Plate
11	305-185	Brake Ass'y	29	305-051M	Clamp
12	100-373	Screw (4)	30	305-044	Adjustable Handle
13	301-535	Rubber Pad (2)	31	139-360	Frame
14	139-356	Handle	32	305-260	Retrofit Kit
15	305-058	Rubber Grip (2)			
16	305-138	Cord Clamp (2)	*	136-131	Chain (Not Shown)
17	331-342	Screw (2)			
18	120-021	Nut (2)			

