

和文取扱は、裏面にあります

This manual contains IMPORTANT WARNINGS and INSTRUCTIONS. Equipment in this manual is exclusively for painting purposes. Do not use for other purposes. The operator shall be fully conversant with the requirements stated in this instruction manual including important warnings, cautions and operation and correct handling. Read and understand the instruction manual, before use and retain for reference.

INSTRUCTION MANUAL (For Oversea's Sales)

## Spray Gun

Long nozzle option for W-100

# LW-10/LW-18

### Main Specifications

Maximum Working Pressure	6.8 bar (98 PSI)
Noise level (LAeqT)	72.3 dB(A)
Temperature range	5~40 °C

How to read model names

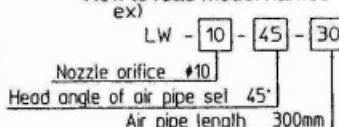

Our products are produced as per international standards ISO9001

Model	Type of feed	Nozzle orifice φ mm(in)	Air cap set	Spray Pattern shape	*1 Atomizing air pressure bar (PSI)	Fluid output ml/min	Spray distance mm(in)	Head Angle of air pipe set	Air pipe length mm(in)	Air consumption l/min(cfm)	Pattern Width mm(in)	Weight g(lbs)	
LW-10-0015	Pressure	1.0(0.039)	W-100 E1	Only fan pattern	3.0 (43)	150	200(7.9)	0°	150 (5.9)	90(3.2)	175(6.9)	480 (1.06)	
LW-10-4515								45°				530 (1.17)	
LW-10-9015								90°				600 (1.32)	
LW-10-0030								0°				300 (11.8)	530 (1.17)
LW-10-4530								45°				300 (11.8)	600 (1.32)
LW-10-9030								90°				500 (19.7)	600 (1.32)
LW-10-0050		1.8(0.071)	W-100 N1		3.5(50)	250	250(9.8)	0°	150 (5.9)	210(7.4)	185(7.3)	480 (1.06)	
LW-10-4550								45°				530 (1.17)	
LW-10-9050								90°				600 (1.32)	
LW-18-0015								0°				300 (11.8)	530 (1.17)
LW-18-4515								45°				300 (11.8)	600 (1.32)
LW-18-9015								90°				500 (19.7)	600 (1.32)

\*1. Atomizing air pressure means air pressure at gun inlet when trigger is pulled and air flows.  
\*2. Fan pattern application only.

## PARTS LIST

No.	Description	Q'ty
1	Air cap set	1
2	Fluid nozzle	1
3	Air pipe set	1
4	O ring	1
5	Fluid pipe set	1
6	Needle packing set	1
7	Needle packing seat	1
8	Body set	1
8-1	Air nipple	1
8-2	Fluid nipple	1
9	Plug	1
10	Air valve shaft	1
11	Air valve seat set	1
11-1	O ring	1
12	Air valve	1
13	Air valve spring	1
14	Fluid adj. guide	1
15	Fluid needle guide	1
16	Fluid needle set	1
17	Fluid needle spring	1
18	Fluid adj. knob	1
19	Air adj. set	1
20	Trigger stud	1
21	Trigger	1
22	E stopper	1
23	Brush	1
24	Instruction manual	1
25	O ring	1

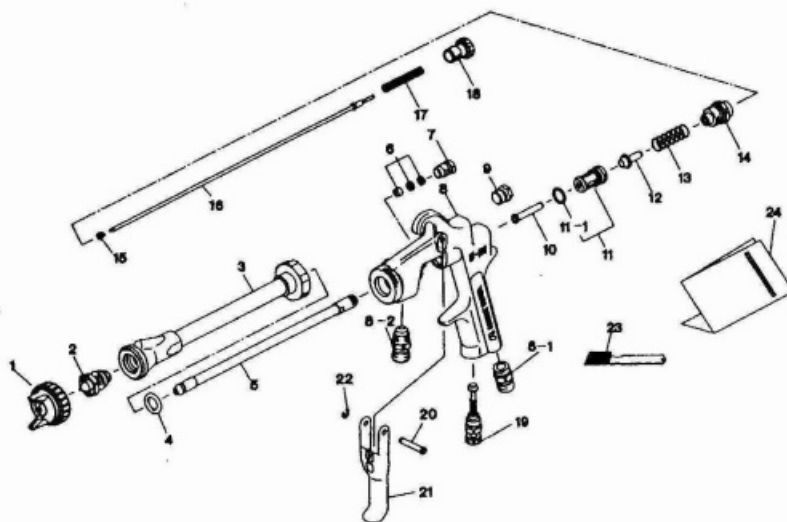

Mark on fluid needle set

Air pipe length	Mark
150 mm (5.9 in)	LW10-15
300 mm (11.8 in)	LW10-30
500 mm (19.7 in)	LW10-50

Fluid needle guide (No.15) is equipped only 500 mm long nozzle model with. When ordering parts, specify gun's model, part name with ref. No. and marked No. of air cap set, fluid nozzle.  
◆ Marked parts are wearable parts.

## ■ SAFETY WARNINGS

### ⚠ FIRE OR EXPLOSION HAZARD

1. Fluid and solvents can be highly flammable or combustible.
  - Use in well-ventilated spray booth.
  - Avoid any ignition sources such as smoking, open flames, electrical hazard, etc.
2. NEVER use HALOGENATED HYDROCARBON SOLVENTS (1.1.1 TRICHLORINE, ETHYL CHLORIDE, etc.), which can chemically react with aluminum and zinc parts and cause an explosion. Be sure that all fluids and solvents used are chemically compatible with aluminum and zinc parts.
3. To reduce the risk of static sparking, grounding continuity to the spray equipment and object being sprayed must be maintained.



### ⚠ MISUSE HAZARD

1. NEVER point gun in the direction of human body.
2. NEVER exceed the maximum safe working pressure of the equipment.
3. ALWAYS release air and fluid pressures before cleaning, disassembling or servicing. For emergency stop and prevention of unintended operation, a ball valve installed near the gun to stop air supply is recommended.



### ⚠ HAZARD CREATED WHILE COATING MATERIALS ARE ATOMIZED AND SPRAYED

1. Toxic vapors produced by spraying certain materials can create intoxication and serious damage to health.
  - Use the gun in well-ventilated areas.
  - Always wear protective eyewear, gloves, respirator, etc., to prevent the toxic vapor hazard, solvents and paint from coming into contact with your eyes or skin.
2. Noise level mentioned in main specifications was measured at 1.0 m behind the tip of the gun, 1.6 m height from floor.
  - Wear earplugs if required.



### ⚠ OTHER HAZARDS

1. NEVER modify this product for any applications.
2. NEVER enter working areas of robots, reciprocators, conveyors, etc., unless machines are switched off.
3. NEVER spray foods or chemicals through the spray gun.
4. If something goes wrong, immediately stop operation and find the cause. Never use till you have solved the problem.

## ■ INSTALLATION

### IMPORTANT

This gun should be operated by adequately trained operators only. Ensure that the gun has not been damaged during transportation. Clean, dry air should be supplied to the gun. When you use this gun for the first time after purchasing, adjust fluid needle packing set. slowly tighten fluid packing seat and loosen a bit when fluid needle set does not return smoothly, and adjust so that fluid needle set smoothly moves.

1. Connect an air hose to air nipple tightly.
2. Connect a fluid hose or a container to fluid nipple tightly.
3. Flush the gun fluid passage with a compatible solvent.
4. Pour paint into container, test spray and adjust fluid output and air volume.

## HOW TO OPERATE

Suggested air pressure is 3.0 to 3.5 bar (43 to 50 psi).

Recommended paint viscosity differs according to paint property and painting conditions. 15 to 23 sec. / Ford #4 is recommendable.

Keep fluid output as small as possible to the extent that the job will not be hindered. It will lead to better finishing with fine atomization.

Set the spray distance from the gun to the work piece as near as possible within the range of 150-200 mm (5.9-7.9 in).

Air pipe set can rotate by 360°.

Loosen cover on air pipe set, not air cap cover, then set the position of gun head.

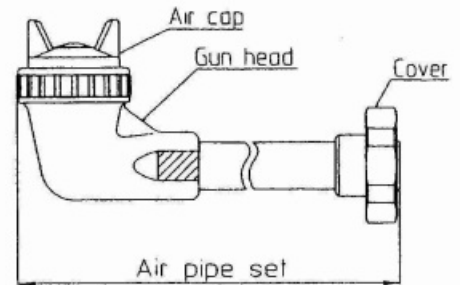

## MAINTENANCE AFTER PAINTING

### ⚠ WARNING

- TURN OFF AIR AND COATING MATERIALS TO THE GUN AND RELEASE PRESSURE BY TRIGGERING THE GUN BEFORE DISASSEMBLING, CLEANING OR SERVICING.
- PAY ATTENTION WHEN DISASSEMBLING SPRAY GUN SINCE YOU MUST TOUCH SHARP PARTS.
- DO NOT DISASSEMBLE WITHOUT RECEIVING ENOUGH KNOWLEDGE AND EDUCATION.



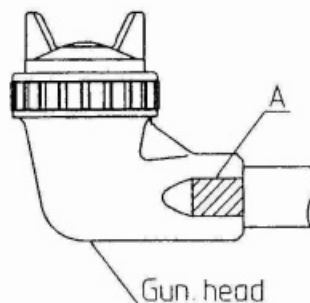



1. Pour remaining paint into another container and then clean paint passages and air cap. Spray a small amount of thinner to clean paint passages. Incomplete cleaning will cause adverse pattern shape and particles. Clean fully and promptly two-component paint after use.
2. Clean other sections with attached brush soaked with thinner and waste cloth.
3. Clean paint passages fully before disassembly.
4. While keeping fluid needle set inserted, tighten fluid needle packing set by hand. Then tighten gradually by spanner. Adjust packing set while pulling trigger and watching movement of fluid needle set since too much tightening will slow down movement of fluid needle and result in leakage from tip of nozzle. If tightened too much, turn counterclockwise to the sufficient position without stuck needle and fluid leakage.
5. Turn air adj. knob counterclockwise to fully open. And then tighten air adj. guide into gun body.
6. Grasp following A part on gun head with spanner, then remove fluid nozzle.



### ⚠ CAUTION

- NEVER USE COMMERCIAL OR OTHER PARTS INSTEAD OF ANEST IWATA ORIGINAL SPARE PARTS.
- NEVER IMMERSE THE WHOLE GUN INTO LIQUID SUCH AS THINNER.
- NEVER DAMAGE HOLES OF AIR CAP, FLUID NOZZLE AND FLUID NEEDLE.

# ■ TROUBLESHOOTING

Spray Pattern	Problems	Remedies
 Fluttering	1. Air enters between fluid nozzle and tapered seat of gun body. 2. Air is suctioned from fluid needle packing. 3. Air enters from O ring at fluid pipe set.	1. Remove fluid nozzle to clean seat. If it is damaged, replace nozzle. 2. Tighten fluid needle packing. 3. Replace O ring.
 Crescent	1. Paint buildup on air cap partially clogs horn holes. Air pressure from both horns differs.	1. Remove obstructions from horn holes. But do not use metal objects to clean horn holes.
 Inclined	1. Paint buildup on air cap partially clogs horn hole or air cap center hole, or causes damage. 2. Loose fluid nozzle.	1. Remove obstructions. Replace if damaged. 2. Remove fluid nozzle and clean seated section.
 Split	1. Paint viscosity too low. 2. Fluid output too high.	1. Add paint to increase viscosity. 2. Adjust fluid adj. knob or pattern adj. knob.
 Heavy Center	1. Paint viscosity too high. 2. Fluid output too low.	1. Reduce viscosity. 2. Increase fluid output.
 Spit	1. Fluid pipe set and fluid needle set are not seated properly. 4. The first-stage travel of trigger (when only air discharges) decreases. 3. Paint buildup inside air cap set.	1. Clean or replace fluid pipe set and fluid needle set. 2. Replace fluid nozzle and fluid needle set. 3. Clean air cap set.

R1: retighten R2: adjust R3: clean R4: replace parts

Problem	Where it occurred	Parts to be checked	Cause	Remedy			
				R1	R2	R3	R4
Air leaks (from tip of air cap)	Air valve set	Air valve	* Dirt or damage on seat			○	○
		Air valve seat set	* Dirt or damage on seat * Wear on air valve spring			○	○
		O ring	* Damage or deteriorated				○
Paint leaks	Fluid nozzle	Fluid pipe set- fluid needle set	* Dirt, damage, wear on seat * Loose fluid needle adj. knob * Wear on needle spring		○	○	○
		Fluid nozzle- Air pipe set	* Insufficient tightening * Dirt or damage on seat	○		○	○
		Fluid needle- packing set	* Needle does not return due to packing set too tight * Needle does not return due to paint buildup on fluid needle		○	○	○
	Fluid needle	Needle packing set- needle set	* Wear	○			○
		Packing seat	* Insufficient tightening	○			
	Fluid pipe set	O ring	* Damage or deteriorated				○
Paint does not flow	Tip of gun	Fluid adj. knob	* Insufficient opening		○		
		Tip hole of nozzle	* Clogged			○	
		Paint filter	* Clogged			○	○



**ANEST IWATA Corporation**

3176, Shinyoshida-cho, Kouhoku-ku  
Yokohama 223-8501 Japan

Cord. 03554613  
No.1221-4