



AIRLESS UNIT

- ALS 423 TX**
- ALS 333 C**
- ALS 433 C**
- ALS 433 TX**
- ALS 453 C**





Dear Customer,

We thank you for the preference you gave us and we are glad to count you among our customers. We hope the use of this equipment will satisfy you and your staff.

We have first of all designed our products by focusing not only on our experience, but also on the latest mechanical innovations. The products have then been manufactured with first-rate materials and techniques and tested by considering your requirements.

We thank you once again and remember that all our technical services are at your disposal for any present and future requirement.

ANEST IWATA EUROPE TORINO - ITALY

The company ANEST IWATA EUROPE Srl mission is to supply all their product and spray painting equipment users and distributors with the STATE-OF-THE-ART of technology and with continuous innovations, to obtain the best finish at the lowest cost.

Our product range must offer the perfect balance between the energy use and its consequences, to help to safeguard and improve the environment.

All Anest Iwata Europe s.r.l. staff members use their knowledge and skills to provide their customers with an excellent service to satisfy them with high quality and reliability and with continuous innovation.

Our activities, as those of many other companies, are in compliance with several European Directives (Safety and Environment) and International Standards (ISO - Quality and Environment).

As to SAFETY, the standards our products refer to are the CE 89/382 Directive and subsequent; all our items of this type have the CE marking, are supplied with a Technical File which can be consulted on request and are accompanied by a use manual (standardized by the European standards EN 292) available in different languages.

There are also some specific safety standards, that is EN 1953 standard as to spray guns, and **prEN 12621** as to pressure pumping circuits. These standards can be consulted or bought at **UNI**.

As to **QUALITY** standards (**ISO 9001**), ANEST IWATA EUROPE is provided with the ISO 9001 certification. Our company philosophy gives all our partners, distributors and users any possible information, which is very useful for our product use, for the environment safeguard and for the operators' safety.



CONTENTS

USE OF THE MANUAL	Page 4
SYMBOLS USED	4
INFORMATIVE LETTER	5
WARRANTY	7
1. TRANSPORT AND HANDLING	8
1.1 TRANSPORT	8
1.2 TRANSPORT WITH CARDBOARD PACKING	8
1.3 HANDLING	9
1.4 TEMPORARY STORAGE	9
2. PRODUCT IDENTIFICATION	10
2.1 PLATE DATA	10
2.2 THE DIFFERENT MODELS	10
2.3 TECHNICAL SPECIFICATIONS	11
2.4 SAFETY SYSTEMS	15
2.5 WORKABLE PRODUCTS	16
3. OPERATION	17
3.1 OPERATION DESCRIPTION	17
4. INSTALLATION AND STARTING-UP	18
4.1 CHECK ON THE PURCHASED PRODUCT	18
4.2 CONDITIONS FOR INSTALLATION	18
4.3 INSTALLATION	18
4.4 CAUTIONS	19
5. USE	20
5.1 USE	20
5.2 SAFETY RULES DURING USE	20
5.3 CLOTHES	20
5.4 UPPER GASKETS PREWASH AND ADJUSTMENT	21
5.5 STARTING-UP	21
5.6 DAILY INTERRUPTIONS	22
5.7 WRONG AND DANGEROUS USES	23
5.8 PRESSURE RELEASE PROCESS	24
6. MAINTENANCE AND INSPECTION	25
6.1 GENERAL NOTES	25
6.2 SAFETY RULES DURING MAINTENANCE	25
6.3 RECOMMENDED SCHEDULED OPERATIONS	25
6.4 DISASSEMBLY AND RE-ASSEMBLY PROCEDURE	26
6.5 MOTOR GROUP DISASSEMBLY	26
6.6 MOTOR GROUP MAINTENANCE	26
6.7 MOTOR GROUP RE-ASSEMBLY	27
6.8 PNEUMATIC MOTOR DISASSEMBLY FROM THE PUMP ROD	27
6.9 PUMP ROD DISASSEMBLY	28
6.10 PUMP ROD MAINTENANCE	28
6.11 PUMP ROD RE-ASSEMBLY	29
6.12 MOTOR GROUP RE-ASSEMBLY TO THE PUMP ROD	29
6.13 TESTS TO BE CARRIED OUT AFTER RE-ASSEMBLY	29
6.14 PAINT FILTER MAINTENANCE	29
7. TROUBLESHOOTING	30
8. EXPLODED VIEWS WITH SPARE PART LISTS	32
8.1 AIRLESS UNIT ALS 333 C	32
8.2 AIRLESS UNIT ALS 433 C	34
8.3 AIRLESS UNIT ALS 433 TX	36
8.4 AIRLESS UNIT ALS 453 C	38
8.5 AIRLESS UNIT ALS 423 TX	40
9. ACCESSORIES	42
9.1 / 9.2 / 9.3 / 9.4 - ALS ACCESSORIES	43
9.5 DELIVERY FILTER TF-8	44
9.6 DELIVERY FILTER TF-8N	44
9.7 DELIVERY FILTER TF 9	45
9.8 / 9.9 AIR REGULATION UNITS	46
9.10 DIP TUBE WITH FILTER	47
10. DISMANTLING	57



Use of the manual

The use and maintenance manual is the document accompanying the equipment from its manufacture till its dismantling. Therefore, it is an integral part of the equipment.

The manual must be read before starting ANY ACTIVITY involving the equipment including its handling.

For a better consultation the instruction manual is divided into the following sections:

SECTION 1

Transport, packaging, handling and check on the purchased product.

SECTION 2

Description of the equipment and of its field of application.

It also describes all the technical features of the equipment.

This information can be compared to that of an illustrative leaflet.

SECTION 3

Equipment operation.

SECTION 4

Equipment installation.

SECTION 5

Ordinary and extraordinary maintenance.

ENCLOSURES

Exploded view and list of components.

Symbols used

The operations which can be dangerous if they are not carried out correctly, are indicated with the symbol:



The prescriptions given by these symbols refer exclusively to the equipment in compliance with Directive "ATEX" 94/9/EC.



The operations described by these symbols must be carried out by a qualified staff with a specific knowledge of safety in case of potentially explosive atmospheres.

If these prescriptions are not followed, they can cause great danger for safety of people and environment.



The operations requiring a qualified or specialised staff, to avoid any danger, are indicated with the symbol:



It is advisable to train the staff who have to use the equipment and to check if everything is understood and carried out.



Other symbols



Index of the use and maintenance manual



Transport



Description of the equipment



Installation



Ordinary use



Wiring and hydraulic diagrams



Dismantling



Maintenance procedures

Informative

This use and maintenance manual is an integral part of the equipment and it must be easily available to the staff in charge of its use and maintenance.

The user and the maintenance man must know the content of this manual. All the descriptions and pictures contained in this manual are not binding.

Although the main features of this equipment are not subject to change, the manufacturing Company reserves itself the right to change those components, details and accessories it deems necessary to improve the machine or to meet manufacturing or commercial requirements, at any time and without updating this manual immediately.

COMPLIANCE WITH THE STANDARD



All the units are conceived in compliance with the applicable Essential Safety Requirements of the Machinery Directive 98/37/EC.



The units are also designed and manufactured in compliance with the Essential Safety Requirements (ESR) of Annex II of Directive "ATEX" 94/9/EC and they comply with the following classification:

- Equipment group: **II**.
- Category: Gas **2G**.
- Area: Gas **1**
- Maximum superficial temperature: temperature class **T6**.



WARNING

TO ENSURE THE GOOD WORKING OF THE EQUIPMENT AND OF ITS SAFETY DEVICES, THE PUMP MUST BE INSTALLED BY A QUALIFIED STAFF.



WARNING

ALL RIGHTS ARE RESERVED. THE REPRODUCTION OF ANY PART OF THIS MANUAL, IN ANY FORM, IS STRICTLY FORBIDDEN WITHOUT PRIOR WRITTEN AUTHORIZATION OF THE MANUFACTURING COMPANY.

THE CONTENT OF THIS MANUAL CAN BE MODIFIED WITHOUT NOTICE. GREAT CARE HAS BEEN TAKEN IN COLLECTING AND CHECKING THE DOCUMENTATION CONTAINED IN THIS MANUAL TO MAKE IT AS COMPLETE AND COMPREHENSIBLE AS POSSIBLE.



WARNING

THIS USE AND MAINTENANCE MANUAL DOES NOT MAKE UP FOR ANY DESIGN INADEQUACY.

In case of breakdown or malfunction, apply to the CUSTOMER CARE SERVICE.

CUSTOMER SERVICE



ANEST IWATA EUROPE s.r.l.
C.so Vigevano, 46 - 10155 Torino
Telephone +39 011.24.80.868
Telefax +39 011.85.19.44
E-mail: info@anest-iwataeu.com



WARNING

THE ORIGINAL CONFIGURATION OF THE EQUIPMENT MUST NOT BE CHANGED AT ALL.

On receiving the equipment check that:

The supply corresponds to the order specifications.

In case of non-compliance, inform immediately our Technical Services.



Warranty

All **ANEST IWATA** s.r.l. products have a one-year guarantee from the invoice date, unless otherwise stated in writing. The warranty covers all manufacturing faults and material defects. Any spare part replacement or repair operations are covered only if they are carried out by our technicians at our servicing shops.

The faulty parts must be sent **CARRIAGE PAID**.

Once the components have been repaired, they will be sent **CARRIAGE FORWARD** to the customer.

The warranty covers no intervention of our technicians during installation or dismantling operations. If for practical purposes one of our technicians is sent on site, a charge will be made for the time plus extra for travelling and expenses.

Our warranty does not cover direct or indirect damage to people or property caused by our equipment. It covers no repair operations carried out by the customer or by a third party, either.

THE WARRANTY DOES NOT COVER:

- Damage or breakdown caused by improper use or assembly.
- Damage or breakdown caused by the use of spare parts that are different from the original or recommended ones.
- Damage or breakdown caused by a bad preservation.
- Components subject to wear (described in the spare part list).

WARRANTY FORFEITURE:

- In case of delayed payment or other contractual defaults.
- Whenever changes or repairs are carried out on our equipment without prior authorization.
- Whenever the serial number is damaged or removed.
- When the damage is caused by improper use or functioning, or if the equipment falls, is bumped or by other causes not due to the normal working conditions.
- Whenever the unit is disassembled, tampered with or repaired without the authorization of **ANEST IWATA s.r.l.**

All repair interventions carried out under warranty do not interrupt its duration.

All disputes will be settled in the court of justice of Turin.



1.1 Transport

To transport the equipment only the systems described below can be used. In any case make sure that the transport and lifting device can bear the weight of the equipment with its packaging.



WARNING
ALWAYS KEEP THE PACKAGING IN VERTICAL POSITION.



WARNING
IT IS ADVISABLE THAT THE STAFF IN CHARGE OF HANDLING THE EQUIPMENT WEAR PROTECTIVE GLOVES AND SAFETY SHOES.



WARNING
WHILE LIFTING OR HANDLING THE EQUIPMENT OR ANY OF ITS COMPONENTS CLEAR THE WORKING AREA. LEAVE ALSO A SUFFICIENT SAFETY AREA AROUND THE EQUIPMENT TO AVOID DAMAGING PEOPLE OR OBJECTS WHICH COULD BE THERE.

1.2 Transport with cardboard packaging

The equipment is put inside a cardboard packaging and wrapped with some shockproof material.

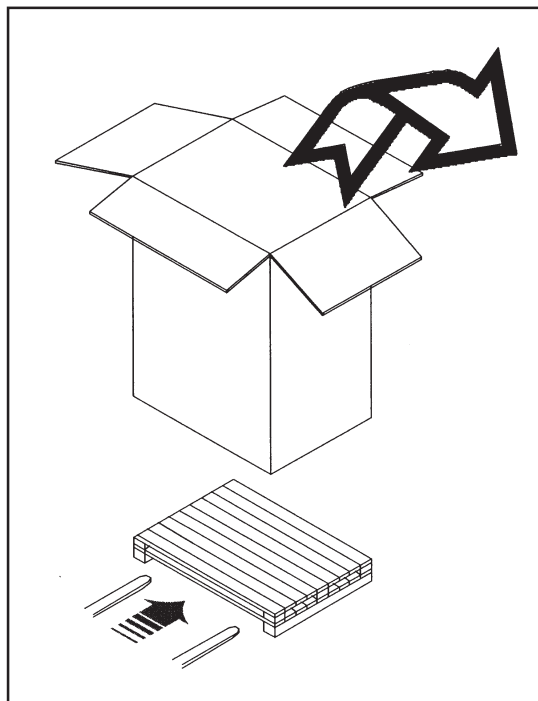



1.3 Handling

To handle the cardboard packaging use a trolley.
To handle or displace the airless unit only use the handle.



WARNING
FOLLOW THE INSTRUCTIONS ON THE PACKAGING BEFORE HANDLING AND OPENING IT.

HANDLING BY MEANS OF HANDLE

HANDLING BY MEANS OF TROLLEY

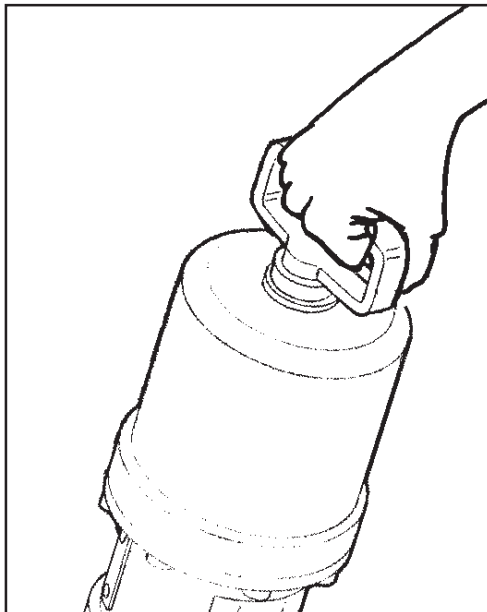

1.4 Temporary storage

During transport and storage make sure the temperatures between 0 and 40° C are not exceeded.

In case of storage, make sure the equipment is not put in places with an excessive humidity.



2.1 Plate data

The manufacturer's identification plate is applied on the airless unit (see picture below).

It must not be removed at all, even if the equipment is resold. For any communication with the manufacturer always mention the serial number written on the plate itself.

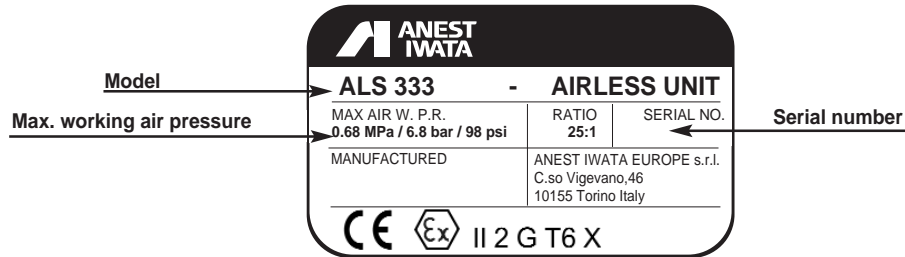

EC marking – 

- Environmental limits (room temperature between + 5°C and + 40°C).
- Maximum superficial temperature: temperature class T6.

2.2 The different models

MODELS FOR SOLVENT BASED PAINT

ALS 333 C: ALS 333 C AIRLESS UNIT

Pump type PP 1251 C on trolley with air adjustment, suction pipe, delivery and suction paint filter, fluid recirculation.

ALS 433 C: ALS 433 C AIRLESS UNIT

Pump type PP 4301 C on trolley with air adjustment, suction pipe, delivery and suction paint filter, fluid recirculation.

ALS 453 C: ALS 453 C AIRLESS UNIT

Pump type PP 4531 C on trolley with air adjustment, suction pipe, delivery and suction paint filter, fluid recirculation.

MODELS FOR WATER BASED PAINT

ALS 433 TX: ALS 433 TX AIRLESS UNIT

Pump type PP 4301 CNE on trolley with air adjustment, suction pipe, delivery and suction paint filter, fluid recirculation and antipulsation hose.

ALS 423 TX: ALS 423 TX AIRLESS UNIT

Pump type PP 4231 NE on trolley with air adjustment, suction pipe, delivery and suction paint filter, fluid recirculation and antipulsation hose.



2.3 Technical specifications

ALS 333 C

MODEL	ALS 33 3C
Pump type	PP1251 C
Dimensions (mm)	500x500x900
Weight	23 Kg
Air pipe fitting	G 1/4"
Fluid pipe fitting	G 1/4"
Paint filter	TF-8
Fluid suction filter	50 Mesh
Max. air working pressure	6.8 bar
Compression ratio	25:1
Max. fluid delivery	2.4 l/min
Delivery/cycle	~ 26 ml/cycle
Max. No. of cycles per minute	92 cycles/min
Cycle stroke	58 mm
Compressor (required power)	> di 0.75 Kw
Working temperature	5~40° C
Noise level	84.1 dB(A)*

* This noise level has been measured in compliance with Machinery Directive 89/392 and with ISO 3744 standards.

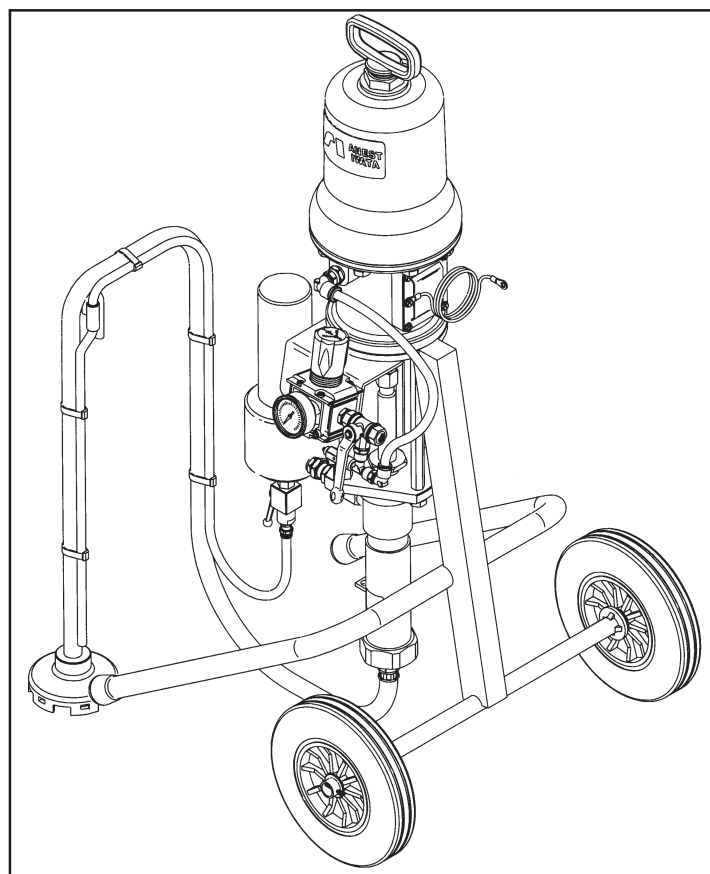



**ALS 433 C
ALS 433 TX**

MODEL	ALS 433 C	ALS 433 TX
Pump type	PP4301 C	PP4301 CNE
Dimensions (mm)	500x500x970	500x500x970
Weight	30 Kg	30 Kg
Air pipe fitting	G 1/4"	G 1/4"
Fluid pipe fitting	G 1/4"	G 3/8"
Paint filter	TF-8	TF-8N
Fluid suction filter	50 Mesh	30 Mesh
Max. air working pressure	6.8 bar	6.8 bar
Compression ratio	30:1	30:1
Max. fluid delivery	4.7 l/min	4.7 l/min
Delivery/cycle	~ 59 ml/cycle	~ 59 ml/cycle
Max. No. of cycle per minute	80 /cyclesmin	80 cycles/min
Cycle stroke	93 mm	93 mm
Compressor (required power)	> di 1.5 Kw	> di 1.5 Kw
Working temperature	5~40° C	5~40° C
Noise level	78.1 dB(A)*	78.1 dB(A)*

* This noise level has been measured in compliance with Machinery Directive 89/392 and with ISO 3744 standards.

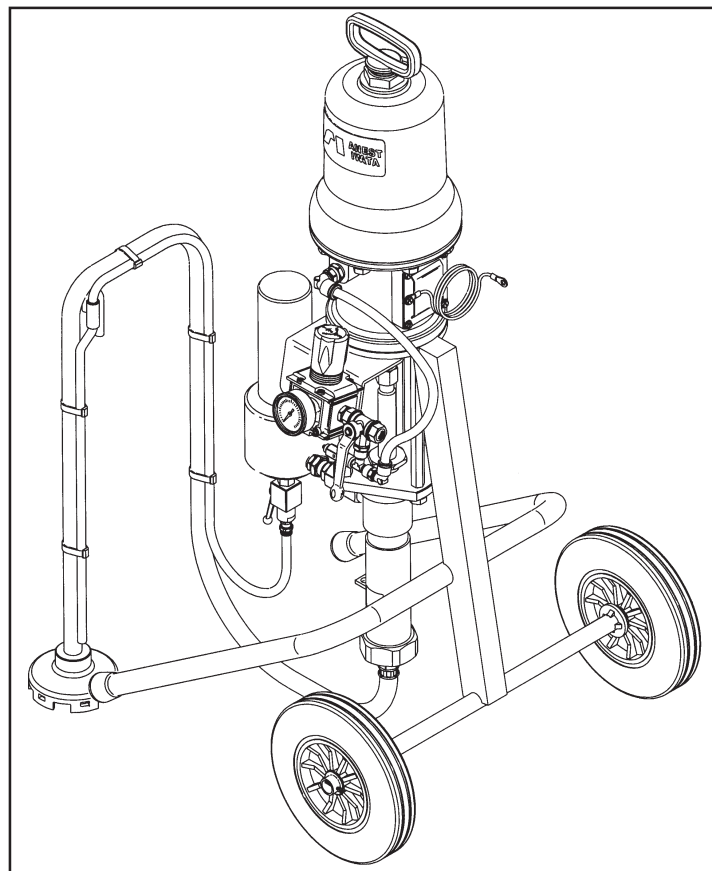



ALS 453 C

MODEL	ALS 453 C
Pump type	PP4531 C
Dimensions (mm)	500x500x970
Weight	30 Kg
Air pipe fitting	G 1/4"
Fluid pipe fitting	G 1/4"
Paint filter	TF 9
Fluid suction filter	50 Mesh
Max. air working pressure	6.8 bar
Compression ratio	53:1
Max. fluid delivery	2.8 litri/min
Delivery/cycle	~ 35 ml/cycle
Max. No. of cycles per minute	80 cycles/min
Cycle stroke	93 mm
Compressor (required power)	> di 1.5 Kw
Working temperature	5~40° C
Noise level	78.6 dB(A)*

* This noise level has been measured in compliance with Machinery Directive 89/392 and with ISO 3744 standards.

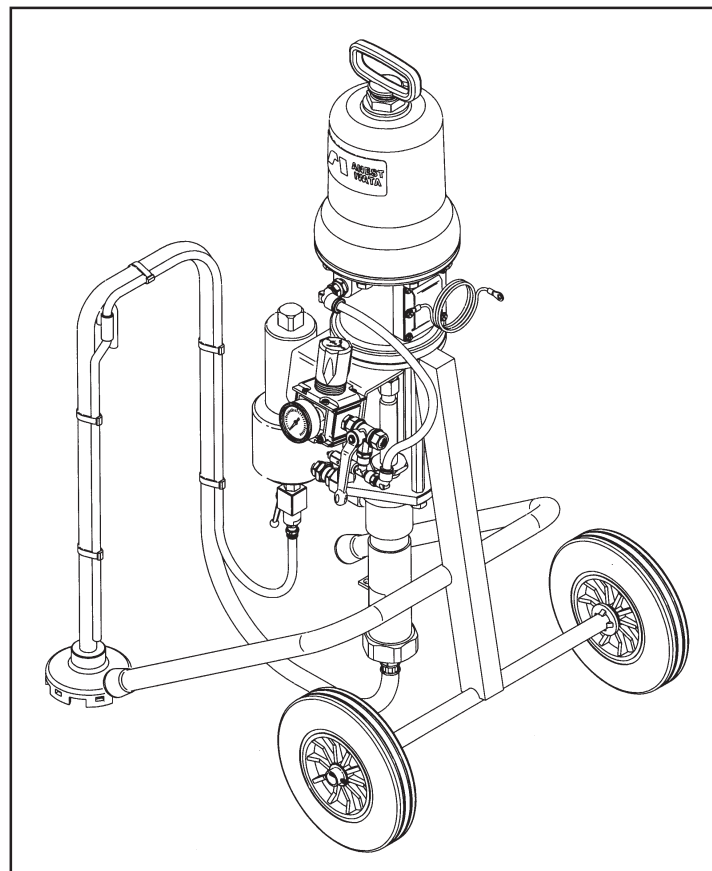



ALS 423 TX

MODEL	ALS 423 TX
Pump type	PP 4231 NE
Dimensions (mm)	500x500x970
Weight	35 Kg
Air pipe fitting	G 1/4"
Fluid pipe fitting	G 3/8"
Paint filter	TF-8N
Fluid suction filter	30 Mesh
Max. air working pressure	6.8 bar
Compression ratio	23:1
Max. fluid delivery	8 litri/min
Delivery/cycle	~ 80 ml/ciclo
Max. No. of cycles per minute	100 cicli/min
Cycle stroke	93 mm
Compressor (required power)	> di 1.5 Kw
Working temperature	5~40° C
Noise Level	78.1 dB(A)*

* This noise level has been measured in compliance with Machinery Directive 89/392 and with ISO 3744 standards.

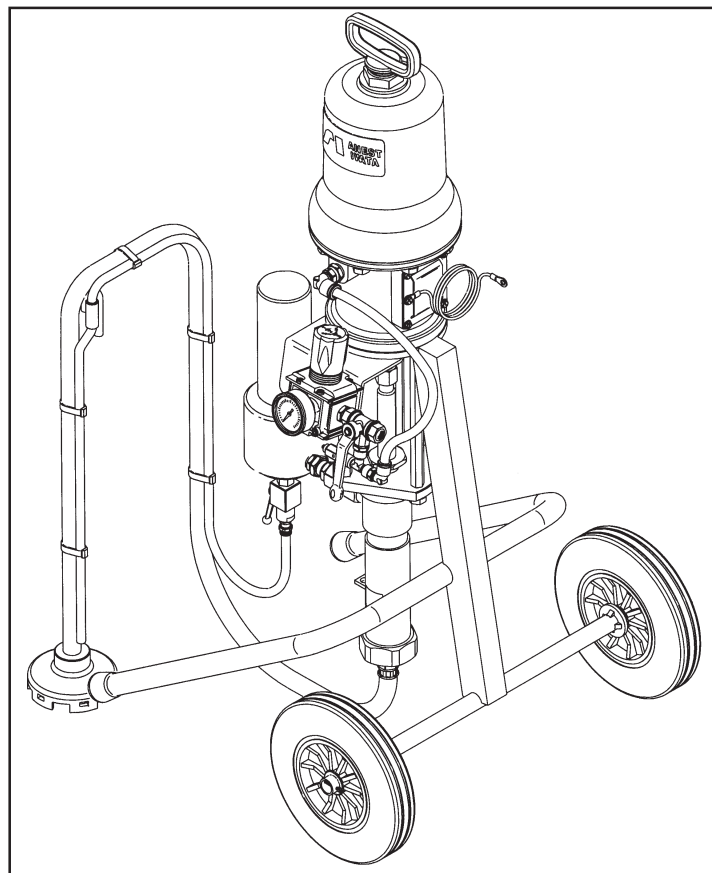



2.4

Safety systems

Several safety systems have been conceived during the airless unit design and manufacture to safeguard the operator, in compliance with pr EN 12621 Directive about paint.



SAFETY INFORMATION

In case of units that are to be used in areas with potentially explosive atmospheres, before starting working the operators must disable the unit power supply, by putting it “out of order”. They also must ensure that the unit cannot be restarted unintentionally.



All further necessary environmental safety measures must be adopted (such as the elimination of gas or residual dusts, etc.).

SAFETY VALVE

A 8 bar calibrated safety valve is installed to ensure the pump working pressure does not exceed the limits inside the feeding circuit.

If the calibration pressure is exceeded, the valve opens by releasing the excess of air.



WARNING

DO NOT REMOVE THE VALVE PLASTIC PROTECTION. ANY TAMPERING WITH COULD BE DANGEROUS FOR THE OPERATOR AND COMPROMISE THE EQUIPMENT GOOD WORKING.

THREE-WAY VALVE

In case of anomalies during working, turn 90° the three-way valve lever. In this way the air supply will be interrupted and the residual pressure inside the pump will be released.





Safety pictograms

Some pictograms can be found on the pump with the safety warnings to follow by anyone who is going to use it.



WARNING

THE MANUFACTURING COMPANY IS NOT TO BE HELD RESPONSIBLE FOR DAMAGE OR ACCIDENTS TO PEOPLE OR THINGS COMING FROM THE NON-COMPLIANCE WITH THE PRESCRIBED RULES. THE RESPONSIBILITY RESTS ENTIRELY WITH THE OPERATOR HIMSELF.

WARNING E 1-Rev. 0	
READ:	Read the enclosed INSTRUCTION MANUAL and all documents before start up operation.
WARNINGS:	Install the pump vertically, and fix it securely.
- INSTALLATION:	Tighten all connections securely before start up operation.
- CONNECTIONS:	
DANGER:	Never use HALOGENATED HYDROCARBON FLUID such as Trichloroethane, Methylene Chloride or a fluids containing such chemical contents.
- FORBIDDEN FLUIDS:	
- INJURY:	Never touch driving parts during pump operations.
- GROUNDING:	Secure the grounding before start up operation.
- PRESSURE RELIEF:	Relieve the air body in the unit before any servicing.



2.5

Workable products

All airless ANEST IWATA pumps are conceived to paint ferrous material in general, wood and plastic.

Models ALS 333 C, ALS 433 C and ALS 453 C are intended for solvent-based paints with a maximum viscosity of 85 sec/Ford #4 (100 sec/NK-2).

Models ALS 423 TX and ALS 433 TX are intended for high viscosity thixotropic water-based paints.

To use the equipment with special products ask for the approval of the manufacturer.

Moreover, the technical features of the unit must be adapted for processing such products.

ANEST IWATA is not liable for any accident due to UNAUTHORISED and non qualified personnel using the pump or personnel using it for purposes that are different from the above-mentioned ones.



WARNING

DO NOT USE:

- ANY HALOGENATED HYDROCARBON SOLVENTS, SUCH AS TRICHLOROETHANE, METHYLENE CHLORIDE OR SOMETHING LIKE THAT;
- ANY INFLAMMABLE OR VERY TOXIC PRODUCTS SUCH AS PETROL, KEROSENE, INFLAMMABLE SOLVENTS OR COMBUSTIBLE GASES;
- ANY HERBICIDE OR PESTICIDE
- ANY RADIOACTIVE FLUID



3. OPERATION

3.1 Operation description

Airless pumps are composed of two main parts: the pneumatic motor and the pumping unit. The pneumatic motor is provided with an internal valve system for changing the movement direction.

The pumping unit is composed of an anti-wear chromium plated suction body (liner) and a rod. The gaskets can be adjusted.

The motor straight and alternate movement produces an equivalent movement in the pumping unit.

A system of valves allows the simultaneous suction and pressurisation of the product to be sprayed, in the two chambers of the suction body, therefore guaranteeing the utmost uniformity during the application

PICTURE 1

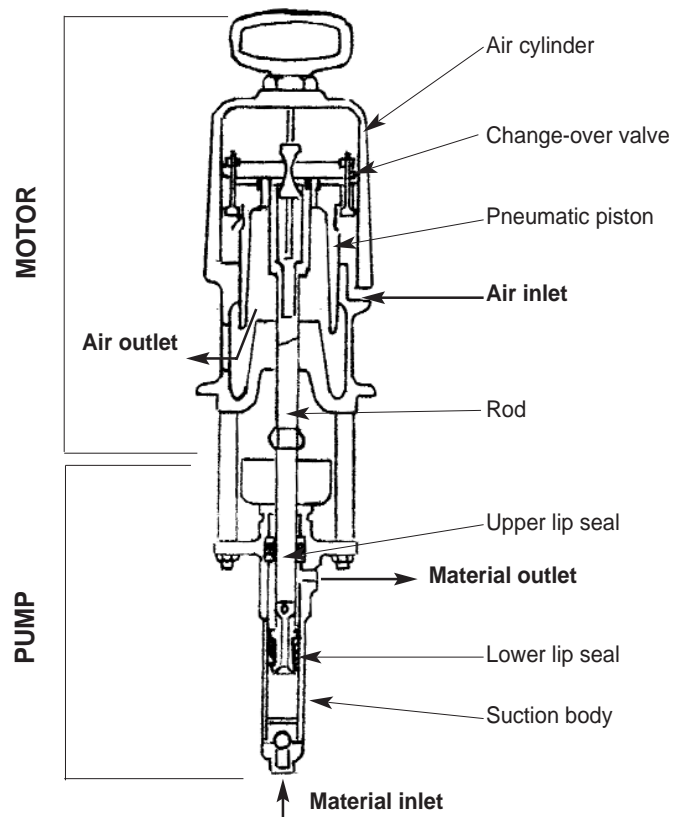



4.1 Check on the purchased product

Before using the pump, make sure it has not been damaged during transport or storage. Also check that all standard components are inside the packaging.

4.2 Conditions for installation



- The installer must know the ATEX classification of the installation area, as well as the risks coming from a potentially explosive atmosphere, by paying attention to the explosion and fire risks so as to adopt the most suitable protections.



- All maintenance, assembly and disassembly operations must be carried out by a qualified staff **outside the area at risk of explosion**.

- Also check that the accessories comply with the essential safety requirements of the ATEX directives. Handle them with great care to avoid changing their features.

- Once installed, clean the unit.

The equipment must be installed by a **specialized and authorized staff**.

In any case, follow the instructions below.

Painting **must preferably take place inside a suitable spray booth equipped with suction device**.

Do not use the unit if the suction device is off.



WARNING

IF PAINTING IS CARRIED OUT OUTSIDE THE SPRAY BOOTH, ALWAYS OPERATE IN A PLACE WITH A RIGHT VENTILATION TO AVOID CONCENTRATING INFLAMMABLE VAPOURS COMING FROM SOLVENTS OR PAINTS.

4.3 Installation

- Place the equipment on the floor, on a horizontal surface.
- Secure it firmly to the ground by means of the trolley fastening bracket (pic. 2 on page 19).
- Connect the suction pipe steadily (pos. A in pic. 2 on page 19) and the material recirculation pipe (pos. B in pic. 2 on page 19).
- Connect the high pressure pipe for paint to the compensating filter.
For models **ALS 423 TX and ALS 433 TX** it is moreover advisable to use the **antipulsation hose supplied with the equipment**.
- Earth the free end of the ground cable directly.
- Connect the airless gun to the other end of the air/paint twin pipe.
- Connect the air supply pipe to the installation.



WARNING

- CHECK THE PROPER TIGHTENING OF ALL FITTINGS, SINCE THEIR SUDDEN OPENING CAN SERIOUSLY INJURE PEOPLE.



WARNING

- CONSULT THE LOCAL CODE FOR DETAILED INSTRUCTIONS RELATIVE TO GROUND CONNECTIONS IN THE WORK AREA AND TO THE TYPE OF SYSTEM USED.

- THE GROUND CABLE (INCLUDED IN THE SUPPLY) MUST HAVE A MINIMUM SECTION EQUAL TO 1.5 mm².

- ONE END OF THE CABLE MUST BE EARTHEN WHILE THE OTHER MUST BE CONNECTED TO THE LID OF THE PNEUMATIC MOTOR SILENCER.



PICTURE 2

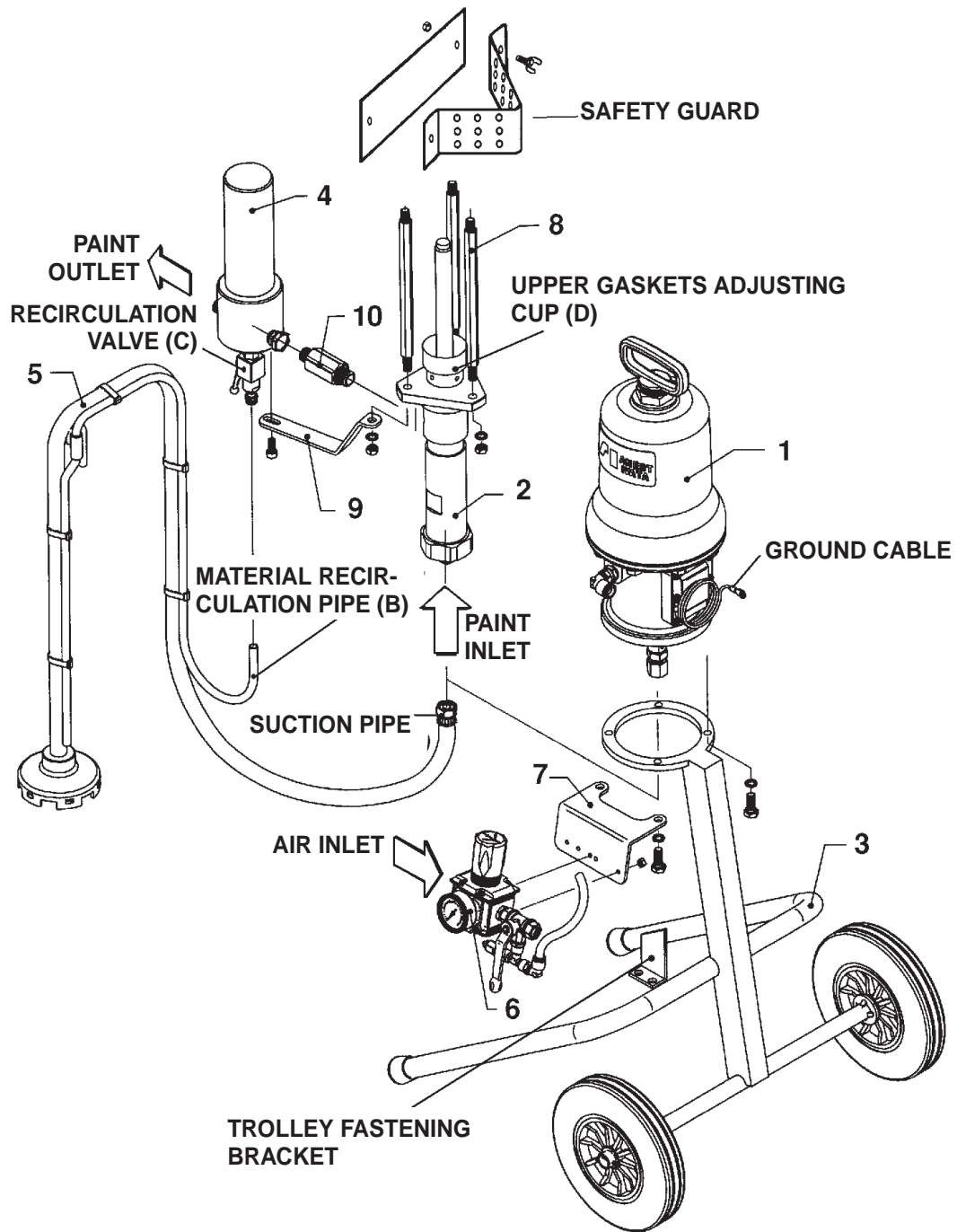

4.4

Cautions



1. Operate the pump with air filtered by means of an air filter with a filtering section smaller than 50 µm; we recommend using a filter with condensate automatic discharge.
2. Do not run the pump idle.
3. Do not spray paint or solvents towards the pump.
4. Do not place the pump close to heat sources or exposed to the sun. Locate it in a place sheltered from water sprinkles.



5.1 Use

This section describes the airless unit use in compliance with the safety standards in force. Read this section carefully.

LIMITS AND CONDITIONS OF USE



Any modification to the constructive shape or to the assembling position is allowed only after asking for ANEST IWATA EUROPE technical service authorization.

If there is no authorization the ATEX approval is no longer valid.



Environmental conditions

- Room temperature: min. + 5°C; max. +40°C

The plate data of the maximum superficial temperatures refer to measures taken in normal environmental conditions and to a normal installation.

Any minimum variation of these conditions can greatly affect the heat development.

5.2 Safety rules during use

TO USE the airless unit **COMPLY WITH** the safety precautions and rules described below.

The manufacturing company declines all responsibility if the operator does not comply with them. It is not to be held responsible for any carelessness during the pump use, either.



If the system is used improperly, it could be broken by causing serious damage.

Use the airless unit for professional purposes only.

Do not change the system; use only Anest Iwata original spare parts.

Check the system daily: repair or replace immediately all worn or damaged parts.

Never exceed the maximum working pressure: 6.8 bar.

IT IS FORBIDDEN to use the equipment for purposes that are different from the ones it is destined to which are described in the use and maintenance manual. If in doubt, apply to your Anest Iwata reseller.

Use paints and solvents compatible with the system parts they come in touch with. Refer to the paint and solvent features mentioned by the manufacturer.

Wear the protective clothes described in section 5.3.

Comply with all the local standards on electric safety and fire risks.

5.3 Clothes

Wear some protective gloves and goggles, an oxygen mask and some ear protections during working. Always follow the laws in force (Ex. LAW 626/94).

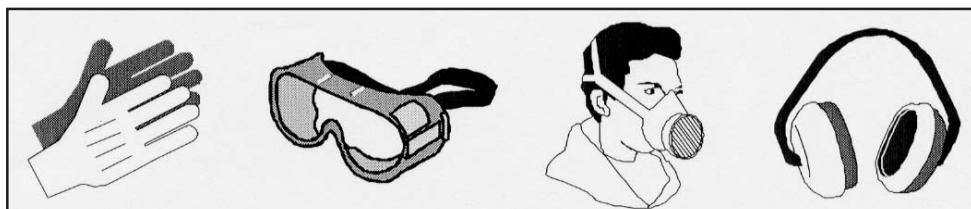



5.4

Prewash

1. Make sure the pump has been properly installed; (see point 4.3)
2. Immerse dip tube (pos. 5 on page 44) in the cleaning liquid (clean solvent or water, according to the purchased model).
3. Place the three-way valve (pos. 3-8 on page 48) in the proper position.
4. Open the recirculation valve (pos. C in pic. 2 on page 19) located on the paint filter.
5. Loosen the upper gaskets adjusting cup (pos. D in pic. 2 on page 19).
6. Gradually open the air pressure regulator up to the minimum pressure required for the straight and alternate movement of the pump (about 0.5 bar).
7. Adjust the upper gaskets by gradually tightening the adjusting cup (pos. D in pic. 2 on page 19) until stopping the cleaning liquid outflow, and the pump movement.
NOTE: The failure to observe this point as well as an improper initial adjustment of the gaskets might reduce their duration.
8. Once the gaskets have been adjusted, increase the air supply pressure (up to about 2 bar) and let the cleaning liquid flow in the recirculation pipe for a few minutes.
9. Close the recirculation valve (pos. C in pic. 2 on page 19), clean the paint pipe and the gun by keeping its trigger pulled.
10. Once you are sure the cleaning has been properly carried out, lift the dip tube from the vessel containing the cleaning liquid and let the residual liquid flow out of the gun first, and then from the recirculation pipe.



WARNING

THE PUMP MUST BE CLEANED BEFORE USING IT FOR THE FIRST TIME, IF IT IS NOT USED FOR A LONG TIME AND AFTER ANY COLOUR CHANGE.

5.5

Starting-up

Before beginning working, start the pump by following the instructions below:

1. Dip the suction pipe in the tank with the product to be pumped.
2. Open the two-way valve for paint recirculation (pos. C in pic. 2 on page 19).
3. Lift and gradually turn the pressure reducer knob (3-2 on page 48). Adjust it at a pressure slightly higher than 2.0 bar, to enable the pump to release the air.
4. Close the two-way valve for paint recirculation (pos. C in pic. 2 on page 19) and release the air through the gun, as well.
5. Increase the pressure of the reducer connected to the pump, according to the desired working pressure.



CAUTIONS

- a) Use airless guns only.
- b) When the paint level inside the tank decreases, the pump might suck some air. Increase the level of paint.
- b) Do not drag the pump by pulling it by the pipes.
- d) Do not spray towards the eyes or towards other people.



CAUTIONS: EMERGENCY STOP

Whenever the pump must be stopped due to one of the following reasons:

- a) The material never stops coming out of the gun
- b) Fluid discharge through the connectors or the damaged pipe. THEN, close the THREE-WAY valve (pos. 3-8 on page 48).



WARNING

- a) When assembling or removing the gun nozzle, always block the trigger by means of the safety catch.
- b) Never remove the gun trigger safety catch.
- c) Never exceed the maximum working pressure (6.8 bar).
- d) Always use a airless ANEST IWATA gun, which is provided with various safety devices.
- e) During functioning, never touch the moving parts. Before carrying out any maintenance operation, disconnect the air supply and discharge the residual pressure.

5.6 Daily interruptions

1. Upon suspending the use of the pump:

- It is not necessary to disconnect the air supply if the interruption is short.
- If the interruption is long, turn the three-way valve (pos. 3-8 on page 48), discharge the air from the circuit and open the recirculation valve (pos. C in pic. 2 on page 19) to release the residual fluid pressure.

2. When the pump is stopped at the end of the working day:

- Clean the fluid passages.
- Remove the dip tube filter, the filter inside the compensator and the gun filter, and clean them.



5.7

Wrong and dangerous uses



A wrong earthing, an insufficient ventilation, a naked flame or a spark can cause a fire or an explosion and provoke some serious injuries.



WARNING

IF SOME SPARKS OR AN ELECTRIC DISCHARGE WERE PERCEIVED, INTERRUPT IMMEDIATELY ALL PAINTING OPERATIONS.
DO NOT USE THE SYSTEM UNTIL THE PROBLEM CAUSE IS IDENTIFIED.

Keep away from the working area all kinds of waste, of solvent container, of solvent or petrol soaked rags or clothes.

Before starting the system disconnect all the electrical connections inside the working area.

Before using the system switch off all the naked flames and pilot lights inside the working area.

Do not smoke inside the working area.

During painting operations, or if there are some vapours in the air, do not switch on or off the lights inside the working area.

Do not use any petrol engine inside the working area.

Some organic solvents or discharged toxic vapours can enter the eyes or the skin, be swallowed or inhaled, by provoking serious injuries.

When the air engine is running, keep the face away from the exhaust.



5.8

Pressure release process



WARNING

1. Close the air supply to the pump by turning the pressure reducer adjustment counter-clockwise down to 0 bar.
 2. Activate the safety catch of the airless gun trigger.
 3. Make sure the recirculation pipe is not clogged, then gradually open the recirculation ball valve, and leave it open.
 4. Hold the gun tightly and lean it against the metal vessel with the paint. Remove the safety catch of the airless gun trigger, and gently pull the trigger to release the pressure inside the airless pipe and inside the gun.
 5. Block the airless gun trigger once more by means of the safety catch.
 6. If you believe the pressure has not been fully released by following the instructions provided in point 4, loosen the gun nozzle carrier to gradually release the residual pressure, then loosen it completely. Clean the fluid passage ducts.
-



6.1

General notes



- Comply with the inspection and ordinary maintenance intervals so as to ensure suitable working conditions and explosion-proof protection.
- Before carrying out any maintenance operation or repair on the internal parts, delay the opening of the unit and wait till it is completely cool to avoid any burning risk due to the presence of hot parts.
- After the maintenance intervention, make sure that all the safety measures are completely and correctly restored.
- Once the maintenance operations/repairs have come to an end, clean the whole unit.
- Use only original spare parts for repairs.

A suitable maintenance is important for a longer duration of the equipment in good working conditions and efficiency ensuring functional safety as time goes by. All maintenance operations must be carried out by a qualified staff. The pump design and the materials used to manufacture it limit the maintenance interventions to a simple periodic cleaning.

The staff must be provided with the individual protections that are generally used for similar operations. They also must follow the safety rules described in section 6.2.

6.2

Safety rules during maintenance

The main rules to follow during maintenance interventions on the unit are:

1. Disconnect the pneumatic supply before replacing any component.
2. Remove safety guard.
3. Do not wear rings, watches, chains, bracelets, etc. during maintenance operations.
4. Always use the individual protections (gloves, safety shoes, etc.).
5. Do not use naked flames, points or pins for cleaning.
6. Do not smoke.

6.3

Recommended scheduled operations

Daily maintenance

- A. Clean the nozzle, the gun paint filter and the compensating filter with a cleaning solvent.
- B. Clean all parts in touch with paint.
- C. Check the good-working order of the safety devices.

Every 50 working hours

- A. Clean the inside of the paint passage ducts with cleaning solvent, especially if highly pigmented paints or paints with many particles tending to deposit are used.
- B. Clean the paint inlet filter.

Every 100 working hours

- A. Clean the inside of the paint passage ducts with cleaning solvent, using a product able to remove all traces of deposited paint.

Every 300 working hours

- A. Inspect and tighten the lip seals of the pump motor.

Every 500 working hours

- A. Grease all motor and air cylinder sliding parts.

Every 1000 working hours

- A. Disassemble all components and clean them thoroughly.
- B. Replace all worn out components.



6.4 Disassembly and re-assembly procedure



WARNING

BEFORE STARTING ANY MAINTENANCE OPERATION REMOVE THE AIR SUPPLY PIPE AND MAKE SURE THE INNER RESIDUAL PRESSURE HAS BEEN RELEASED.

NOTE: The numbering of the follows components refers to the exploded view drawings of Airless Unit in chapter 8.0.

6.5 Motor group disassembly

1. Remove the handle (1), the two nuts (3), the handle gasket (2) and unscrew the cylinder nut (4)
2. Unscrew the air cylinder fixing bolts (31) and disassemble the cylinder itself (6)
3. Push the change-over body downwards and unscrew the valves adjusting nuts (13). During this operation, keep the adjusting valves (23) blocked by means of a slotted screwdriver.
4. Unscrew the two valves (23) from the change-over bar (12) and slip them out.
5. Lifting the change-over rod (15), it is possible to remove the two pins (8), the change-over pivot (9), the change-over body (7), the springs (10) and the change-over bar (12).

PICTURE 3

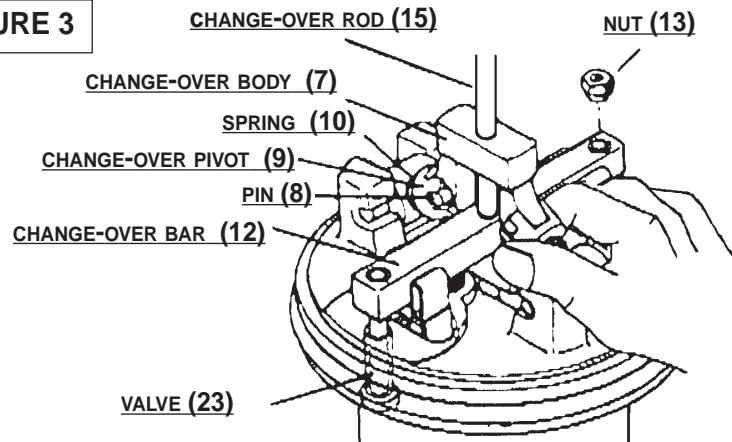

6.6 Motor group maintenance

Any time the motor is disassembled it is recommended to replace the following components:

- 5 O RING
- 16 O RING
- 17 INNER VALVE
- 23 OUTER VALVE
- 26 O RING
- 27 O RING

Moreover, check the wear condition of all the other components, and if necessary replace them



6.7 Motor group re-assembly

Follow the above mentioned procedure in reverse order, bearing in mind the following points:

1. While assembling the valves (23), push the change-over body (7) downwards. Then, screw the valves to the change-over bar (12) and adjust the clearance between the sealing surfaces of the valves and of the piston (18), that must be equal to 2 mm for both.

PICTURE 4

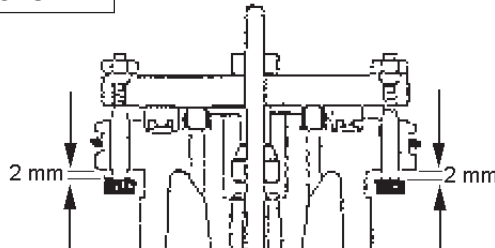

2. Once adjusted, fasten the valves to the change-over bar by means of the two nuts (13), using some thread-brake to prevent subsequent unscrewing.
3. After carrying out the operations provided in point 2 of chapter 6.6 check the clearance (2 mm) once more
4. Grease all components with lithium based grease, caring not to obstruct the air passages.
5. Re-assemble the cylinder (6) and fasten it with the proper screws (31).
6. Lock the change-over rod (15) by means of the two nuts (3), as shown in the picture.

PICTURE 5

**CHANGE-OVER ROD AND
NUT AT THE SAME LEVEL.**

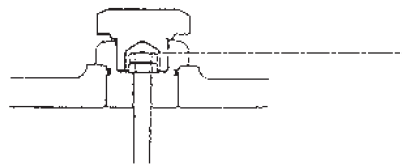

6.8 Pneumatic motor disassembly from the pump rod

1. Keep the rod (39) still and unscrew the joint (38), as shown in picture 6
2. Loosen and undo the three nuts (49).

PICTURE 6

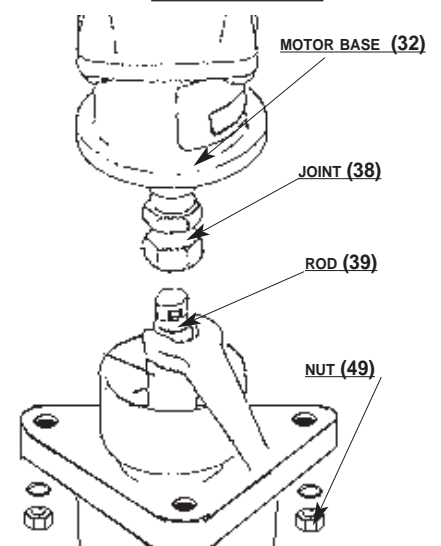



6.9 Pump rod disassembly

1. Secure the suction body (47), unscrew the liner (58) and slip it out.
2. Slip the rod (39) out of the suction body (47).
4. Loosen the adjustment nut (50) and unscrew the upper valve (56).
5. Remove the spacer, the adapters, the gaskets and the upper ball.
6. Unscrew the adjustment cup (40) from the suction body (47) and remove the spacer, the adapters and the gaskets.
7. Unscrew the lower valve (61) from the liner (58) and remove the ball.

6.10 Pump rod maintenance

1. Dip all components in the cleaning liquid and thoroughly clean them.
2. Make sure the rod (39) and the liner (58) are not damaged. If they show deep scratches in the sliding areas, replace them.
3. Make sure the upper valve (56) and the lower valve (61) are not damaged, especially in the area in touch with the ball. If any anomaly is found, replace them.
4. Whenever the pumping unit is completely disassembled, it is advisable to replace the following components:
 - 46 **UPPER GASKETS SET**
 - 54 **LOWER GASKETS SET**
 - 55 **BALL**
 - 60 **BALL**

Moreover, check the wear conditions of all the other components and replace them if necessary

NOTE: For model ALS 423 TX the two sets of gaskets (pos. 46 and pos. 54) can also be composed of 6 or 8 gaskets. As a matter of fact, replacing the spacer (pos. 52 or pos. 43) with a thinner one it is possible to locate 6 gaskets. While removing the spacer (pos. 52 or pos. 43) completely, it is possible to mount up to eight gaskets.



6.11 Pump rod re-assembly

Reverse the above mentioned procedure bearing in mind the following points:

1. Adjust the lower gaskets in order to obtain a “smooth sliding movement of the liner”.
NOTE: If the gaskets are too tight their duration shall result extremely reduced.
The regular and proper adjustment, together with suitable maintenance, ensures a long lasting duration of the gaskets.
2. Do not use grease to lubricate the sliding parts of the pump rod, since it might compromise the following painting operations.

6.12 Motor group re-assembly to the pump rod

1. In order to align the two parts (pneumatic motor and pump rod) in the best position, it is advisable to tighten the three nuts (49) and the liner (58) completely, with the pump running. (Air pressure 0.5 bar).
This procedure allows a further reduction of the adjustable gaskets wear.

6.13 Tests to be carried out after re-assembly

1. The pump must start with a supply pressure equal to at least 1.5 bar.
2. Check for possible air and paint spillage. If necessary, tighten the relevant components.

6.14 Paint filter maintenance

If the pump is properly used (a thorough cleaning is carried out each time it is used) the paint filter does not require special maintenance operations, besides those related to the cleaning and replacement of the filter itself.

If there is some solidified paint inside the filter or inside the paint passages, disassemble it completely, clean it carefully and re-assemble it.



Inconvenience	Cause	Check	Solution
1. The air pressure does not increase	a) The three-way valve is not in the proper position	a) Make sure the three-way valve is in the proper position	a) Adjust the three-way valve in the proper position.
	b) The air regulator is not open	b) Check the proper functioning of the regulator	b) If it is closed, open it. If it is damaged, replace it.
	c) Insufficient air pressure	c) Check the proper functioning of the manometer pressure gauge	c) If the compressor does not supply enough air pressure, replace it with one of greater capacity.
2. The paint does not flow out of the gun	a) Clogged paint filter or paint circuit	a) Opening the recirculation valve the paint does not flow out b) Opening the recirculation valve the paint flows out regularly, but not when pulling the gun trigger	a) The paint circuit is obstructed from the pump inlet to the fluid pipe fitting. Check the paint circuit and remove the material obstructing the passage. b) The paint course, from the gun nozzle to the fluid pipe fitting, is blocked. Check for the obstructed point and remove the clogging; this inconvenience is usually caused by the obstruction of the gun filter.
	b) Clogged nozzle	b) Remove the nozzle and pull the trigger of the gun	b) If the paint flows out it means that the nozzle is clogged. Free the nozzle with a steel pin and clean it with a non-metallic brush soaked in the suitable solvent.
	c) Jammed safety stop		c) Unlock the safety valve.
3. The pump does not work	a) The air does not supply the pneumatic motor	a) Check the air supply pipe	a) Replace it if spoilt or clogged.
	b) The equipment has a technical problem	b) Separate the pneumatic motor from the pumping group and test it using a different air pipe	b) If the motor is running properly, follow the instructions provided in the solution column, point 2 (a - b) c) If the motor is not running properly, disassemble the cylinder and inspect it. In case of special anomalies, ship it to our Customer Care Technical Service.



Inconvenience	Cause	Check	Solution
4. The pump does not stop	a) Some air got inside the paint ducts	a) Make sure the dip tube is properly connected	a) Tighten the dip tube fitting.
	b) Some air remains inside the paint ducts	b) Make sure the paint is in good conditions and that the dip tube suction filter set is fully dipped in the product to be pumped	b) If the paint is in standard conditions increase its level at least until it fully covers the dip tube filter set. Then, carry out the start-up operations relative to the release of air from the paint ducts.
	c) Damaged or dirty valves (upper or lower)	c) Disassemble both and inspect both the valve and the ball	c) Clean them if they are encrusted with solidified paint residues. Otherwise, if they are damaged replace them.
	d) The lower lip seals (inside the liner) are not tight	d) Disassemble the liner and check their wear conditions	d) If it is enough, adjust them. Otherwise, if they are irreparably worn out, replace them.
	e) Leakage from the paint ducts	e) Inspect all the paint ducts	e) If any leakage is found, see to its fixing.
	f) The recirculation valve is not closed		f) Close the recirculation valve.
5. The spray-fan size keeps changing	a) Worn out lip seals	a) The pump does not stop	a) If it is enough, adjust them. Otherwise, replace them if they are worn out.
	b) Damaged or dirty valves or balls	b) The pump does not stop	b) Disassemble and clean them. Replace them if they are
	c) Worn out inner or outer valves (pos. 23 and 17) placed inside the air motor.	c) There is a leakage noise	c) Replace the valves.
	d) Worn out gun nozzle		d) Replace it.
	e) Dirty paint filters		e) Clean or replace them.
6. The air manometer indicates the presence of pressure even though the air regulator is closed	a) Damaged air regulator		a) Replace it.



8.1

AIRLESS UNIT ALS 333 C

Ref. Picture on the next page

Posit.	Description	Posit.	Description
1	HANDLE	59	GASKET
2	GASKET	60	● BALL
3	ROD NUT	61	○ LOWER VALVE
4	MOTOR NUT	62	PIN
5	O RING	68	SAFETY GUARD
6	AIR CYLINDER	69	PLATE
7	CHANGE-OVER BODY	70	NUT
8	PIN	71	SCREW
9	CHANGE-OVER PIVOT		
10	SPRING		
11	SPRING SEAT		
12	CHANGE-OVER BAR		
13	VALVES ADJUSTMENT NUT		
14	WASHER		
15	CHANGE-OVER ROD		
16	● PISTON O RING		
17	● INNER VALVE		
18	AIR PISTON		
19	SCREW		
20	SILENCER FILTER		
21	BAR SEAT		
22	REINFORCEMENT PLATE		
23	● OUTER VALVE		
24	MOTOR ROD		
25	SPLIT PIN		
26	● O RING		
27	O RING		
28	RETAINER		
29	WASHER		
30	SPRING WASHER		
31	BOLT		
32	MOTOR BASE		
33	PLATE		
34	SCREW		
35	LID		
36	BUSHING		
37	RETAINER		
38	JOINT		
39	○ ROD		
40	ADJUSTMENT CUP		
41	BUSHING		
42	UPPER FEMALE ADAPTER		
43	UPPER SPACER		
44	LOWER MALE ADAPTER		
45	CONNECTION SHAFT		
46	● UPPER GASKETS SET		
47	SUCTION BODY		
48	SPRING WASHER		
49	HEXAGON NUT		
50	NUT		
51	UPPER MALE ADAPTER		
52	LOWER SPACER		
53	LOWER FEMALE ADAPTER		
54	● GASKETS SET		
55	● BALL		
56	○ UPPER VALVE		
57	GASKET		
58	○ LINER		

● Most wearable parts.

○ To check on every maintenance.



PUMP TYPE PP1251 C

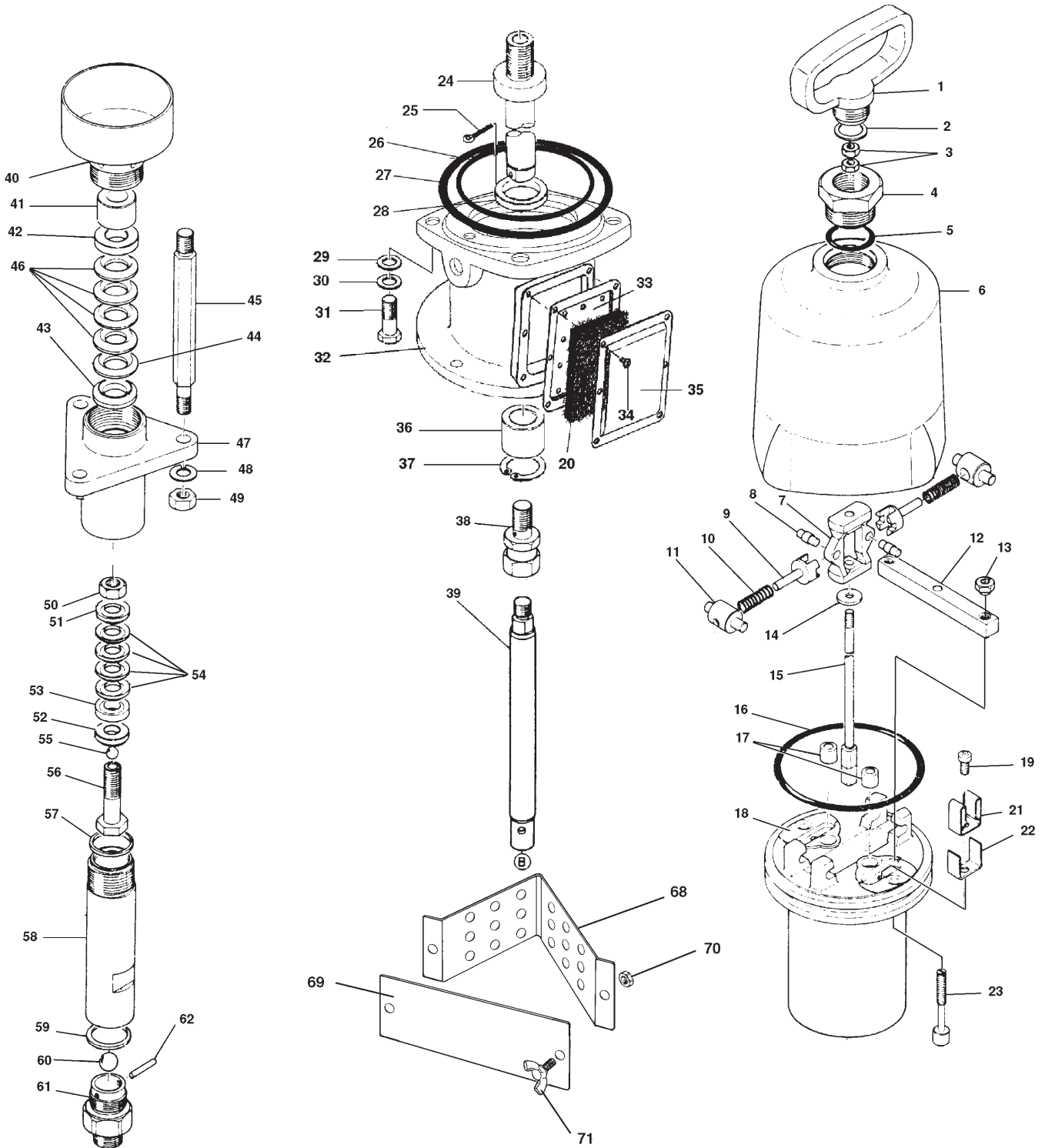



8.2

AIRLESS UNIT ALS 433 C

Ref. Picture on the next page

Posit.	Description	Posit.	Description
1	HANDLE	59	GASKET
2	GASKET	60 ●	BALL
3	ROD NUT	61 ○	LOWER VALVE
4	MOTOR NUT	62	PIN
5	O RING	63	PIN
6	AIR CYLINDER	68	SAFETY GUARD
7	CHANGE-OVER BODY	69	PLATE
8	PIN	70	NUT
9	CHANGE-OVER PIVOT	71	SCREW
10	SPRING		
11	SPRING SEAT		
12	CHANGE-OVER BAR	● Most wearable parts.	
13	VALVES ADJUSTMENT NUT	○ To check on every maintenance.	
14	WASHER		
15	CHANGE-OVER ROD		
16 ●	PISTON O RING		
17 ●	INNER VALVE		
18	AIR PISTON		
19	SCREW		
20	SILENCER FILTER		
21	BAR SEAT		
22	REINFORCEMENT PLATE		
23 ●	OUTER VALVE		
24	MOTOR ROD		
25	SPLIT PIN		
26 ●	O RING		
27	O RING		
28	RETAINER		
29	WASHER		
30	SPRING WASHER		
31	BOLT		
32	MOTOR BASE		
33	PLATE		
34	SCREW		
35	LID		
36	BUSHING		
37	RETAINER		
38	JOINT		
39 ○	ROD		
40	ADJUSTMENT CUP		
41	BUSHING		
42	UPPER FEMALE ADAPTER		
43	UPPER SPACER		
44	LOWER MALE ADAPTER		
45	CONNECTION SHAFT		
46 ●	UPPER GASKETS SET		
47	SUCTION BODY		
48	SPRING WASHER		
49	HEXAGON NUT		
50	NUT		
51	UPPER MALE ADAPTER		
52	LOWER SPACER		
53	LOWER FEMALE ADAPTER		
54 ●	GASKETS SET		
55 ●	BALL		
56 ○	UPPER VALVE		
57	GASKET		
58 ○	LINER		



PUMP TYPE PP4301C

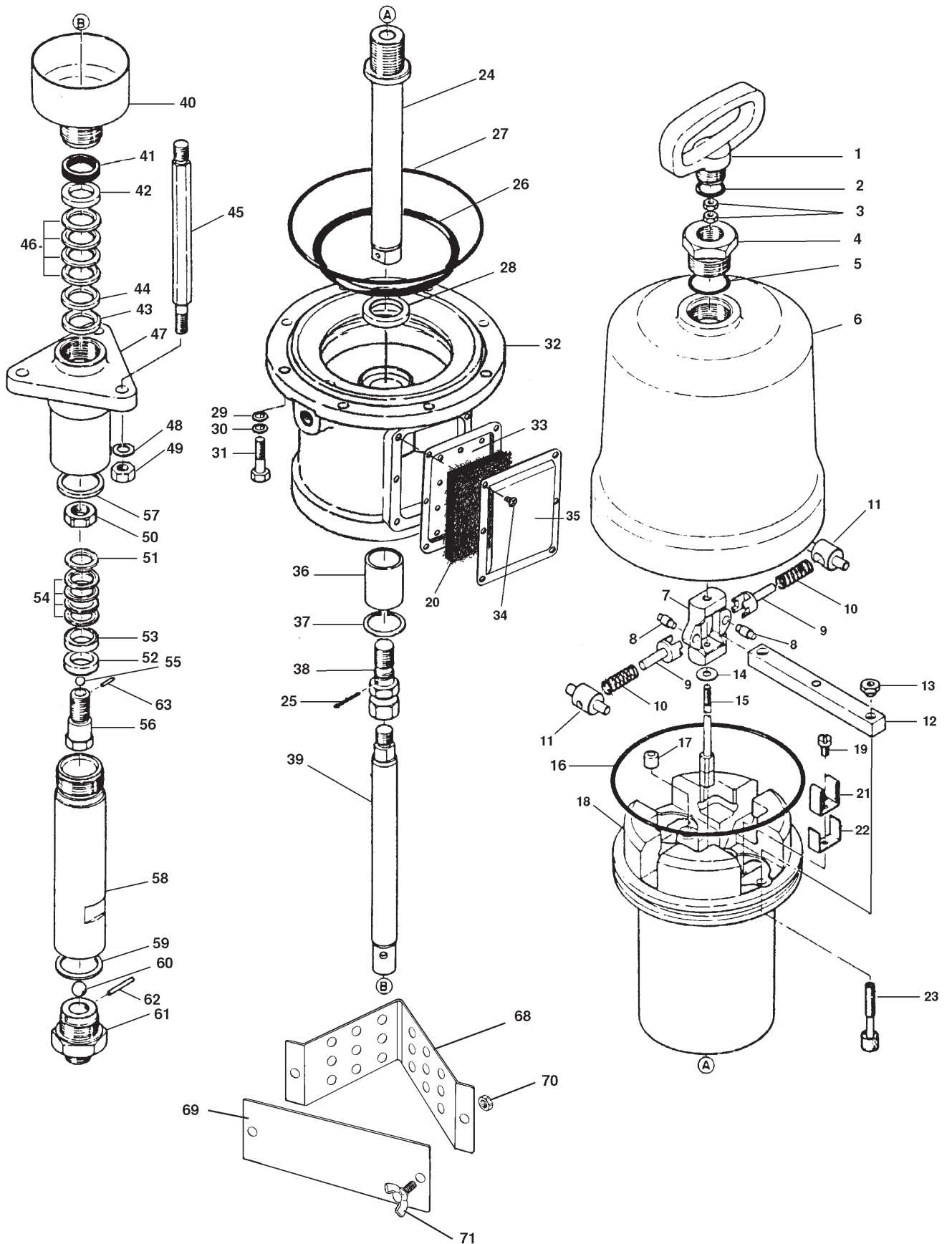



8.4

AIRLESS UNIT ALS 433 TX

Ref. Picture on the next page

Posit.	Description	Posit.	Description
1	HANDLE	59	GASKET
2	GASKET	60 ●	BALL
3	ROD NUT	61 ○	LOWER VALVE
4	MOTOR NUT	62	PIN
5	O RING	63	PIN
6	AIR CYLINDER	68	SAFETY GUARD
7	CHANGE-OVER BODY	69	PLATE
8	PIN	70	NUT
9	CHANGE-OVER PIVOT	71	SCREW
10	SPRING		
11	SPRING SEAT		
12	CHANGE-OVER BAR	● Most wearable parts.	
13	VALVES ADJUSTMENT NUT	○ To check on every maintenance.	
14	WASHER		
15	CHANGE-OVER ROD		
16 ●	PISTON O RING		
17 ●	INNER VALVE		
18	AIR PISTON		
19	SCREW		
20	SILENCER FILTER		
21	BAR SEAT		
22	REINFORCEMENT PLATE		
23 ●	OUTER VALVE		
24	MOTOR ROD		
25	SPLIT PIN		
26 ●	O RING		
27	O RING		
28	RETAINER		
29	WASHER		
30	SPRING WASHER		
31	BOLT		
32	MOTOR BASE		
33	PLATE		
34	SCREW		
35	LID		
36	BUSHING		
37	RETAINER		
38	JOINT		
39 ○	ROD		
40	ADJUSTMENT CUP		
41	BUSHING		
42	UPPER FEMALE ADAPTER		
43	UPPER SPACER		
44	LOWER MALE ADAPTER		
45	CONNECTION SHAFT		
46 ●	UPPER GASKETS SET		
47	SUCTION BODY		
48	SPRING WASHER		
49	HEXAGON NUT		
50	NUT		
51	UPPER MALE ADAPTER		
52	LOWER SPACER		
53	LOWER FEMALE ADAPTER		
54 ●	GASKETS SET		
55 ●	BALL		
56 ○	UPPER VALVE		
57	GASKET		
58 ○	LINER		



POMPA TIPO PP4301 CNE

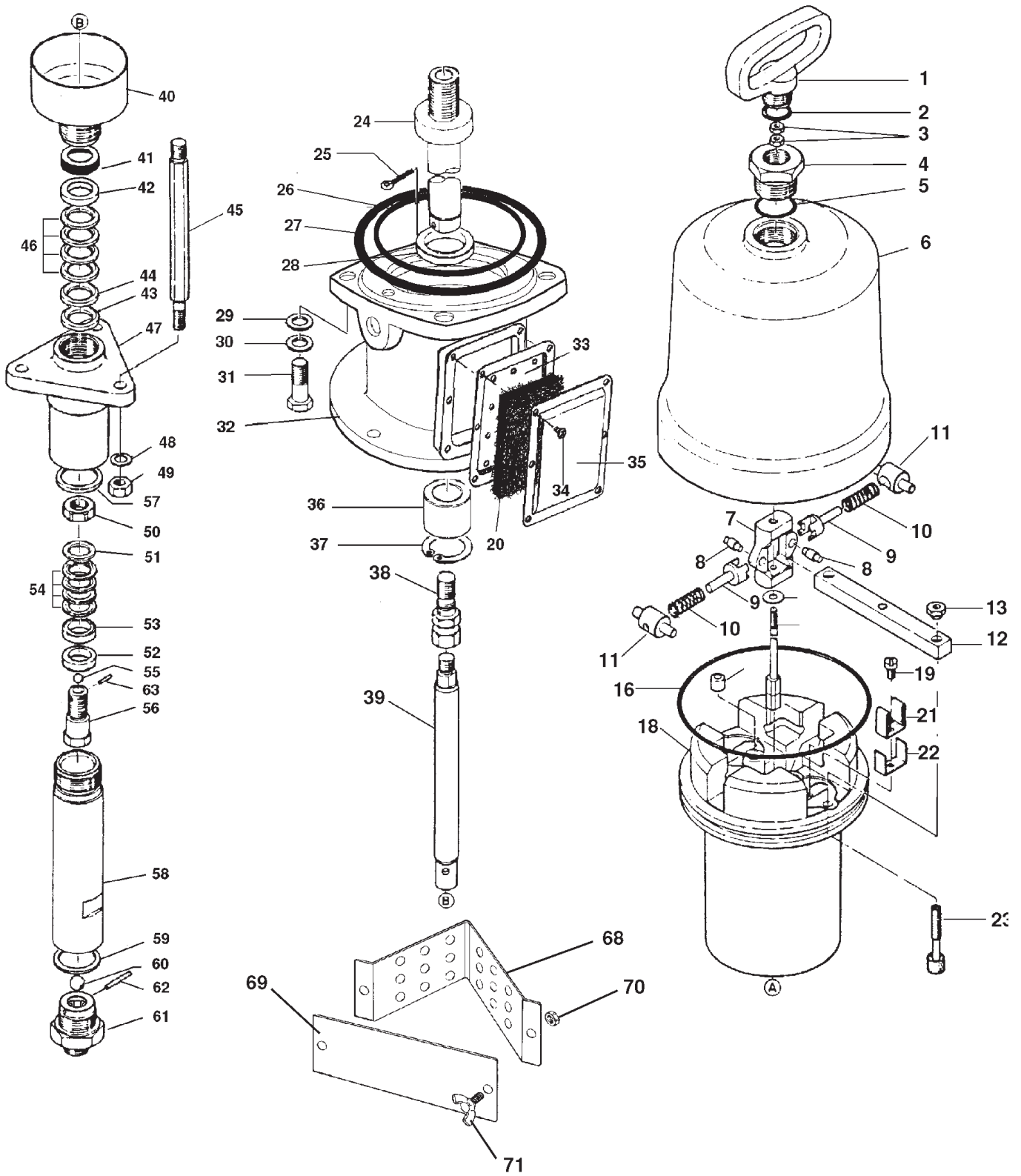



8.5

AIRLESS UNIT ALS 453 C

Ref. Picture on the next page

Posit.	Description	Posit.	Description
1	HANDLE	59	GASKET
2	GASKET	60 ●	BALL
3	ROD NUT	61 ○	LOWER VALVE
4	MOTOR NUT	62	PIN
5	O RING	63	PIN
6	AIR CYLINDER	68	SAFETY GUARD
7	CHANGE-OVER BODY	69	PLATE
8	PIN	70	NUT
9	CHANGE-OVER PIVOT	71	VITE
10	SPRING		
11	SPRING SEAT		
12	CHANGE-OVER BAR	●	Most wearable parts.
13	VALVES ADJUSTMENT NUT	○	To check on every maintenance.
14	WASHER		
15 ●	CHANGE-OVER ROD		
16 ●	PISTON O RING		
17	INNER VALVE		
18	AIR PISTON		
19	SCREW		
21	BAR SEAT		
22	REINFORCEMENT PLATE		
23 ●	OUTER VALVE		
24	MOTOR ROD		
25	SPLIT PIN		
26 ●	O RING		
27	O RING		
28	RETAINER		
29	WASHER		
30	SPRING WASHER		
31	BOLT		
32	MOTOR BASE		
33	PLATE		
34	SCREW		
35	LID		
36	BUSHING		
37	RETAINER		
38	JOINT		
39 ○	ROD		
40	ADJUSTMENT CUP		
41	BUSHING		
42	UPPER FEMALE ADAPTER		
44	LOWER MALE ADAPTER		
45	CONNECTION SHAFT		
46 ●	UPPER GASKETS SET		
47	SUCTION BODY		
48	SPRING WASHER		
49	HEXAGON NUT		
50	NUT		
51	UPPER MALE ADAPTER		
53	LOWER FEMALE ADAPTER		
54 ●	GASKETS SET		
55 ●	BALL		
56 ○	UPPER VALVE		
57	GASKET		
58 ○	LINER		



PUMP TYPE PP4531 C

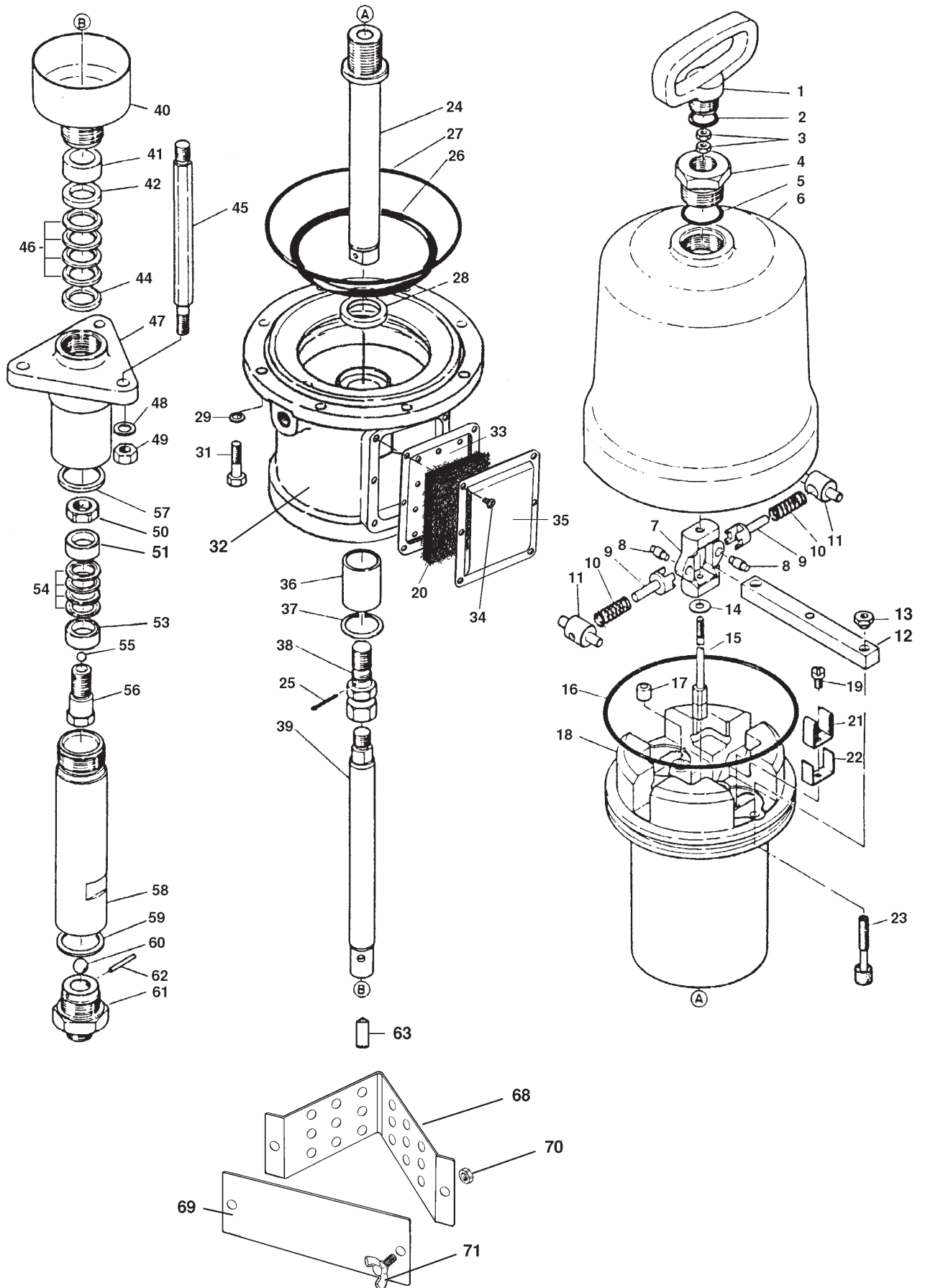



8.6

AIRLESS UNIT ALS 423 TX

Ref. Picture on the next page

Posit.	Description	Posit.	Description
1	HANDLE	59	GASKET
2	GASKET	60	● BALL
3	ROD NUT	61	○ LOWER VALVE
4	MOTOR NUT	62	PIN
5	O RING	63	PIN
6	AIR CYLINDER	64	SCREW
7	CHANGE-OVER BODY	65	SPRING
8	PIN	66	GASKET
9	CHANGE-OVER PIVOT	67	JOINT
10	SPRING	68	SAFETY GUARD
11	SPRING SEAT	69	PLATE
12	CHANGE-OVER BAR	70	NUT
13	VALVES ADJUSTMENT NUT	71	SCREW
14	WASHER		
15	CHANGE-OVER ROD		
16	● PISTON O RING		● Most wearable parts.
17	● INNER VALVE		○ To check on every maintenance.
18	AIR PISTON		
19	SCREW		
20	SILENCER FILTER		
21	BAR SEAT		
22	REINFORCEMENT PLATE		
23	● OUTER VALVE		
24	MOTOR ROD		
25	SPLIT PIN		
26	● O RING		
27	O RING		
28	RETAINER		
29	WASHER		
30	SPRING WASHER		
31	BOLT		
32	MOTOR BASE		
33	PLATE		
34	SCREW		
35	LID		
36	BUSHING		
37	RETAINER		
38	JOINT		
39	○ ROD		
40	ADJUSTMENT CUP		
41	BUSHING		
42	UPPER FEMALE ADAPTER		
43	UPPER SPACER		
44	LOWER MALE ADAPTER		
45	CONNECTION SHAFT		
46	● UPPER GASKETS SET		
47	SUCTION BODY		
48	SPRING WASHER		
49	HEXAGON NUT		
50	NUT		
51	UPPER MALE ADAPTER		
52	LOWER SPACER		
53	LOWER FEMALE ADAPTER		
54	● GASKETS SET		
55	● BALL		
56	○ UPPER VALVE		
57	GASKET		
58	○ LINER		



PUMP TYPE PP4231 NE

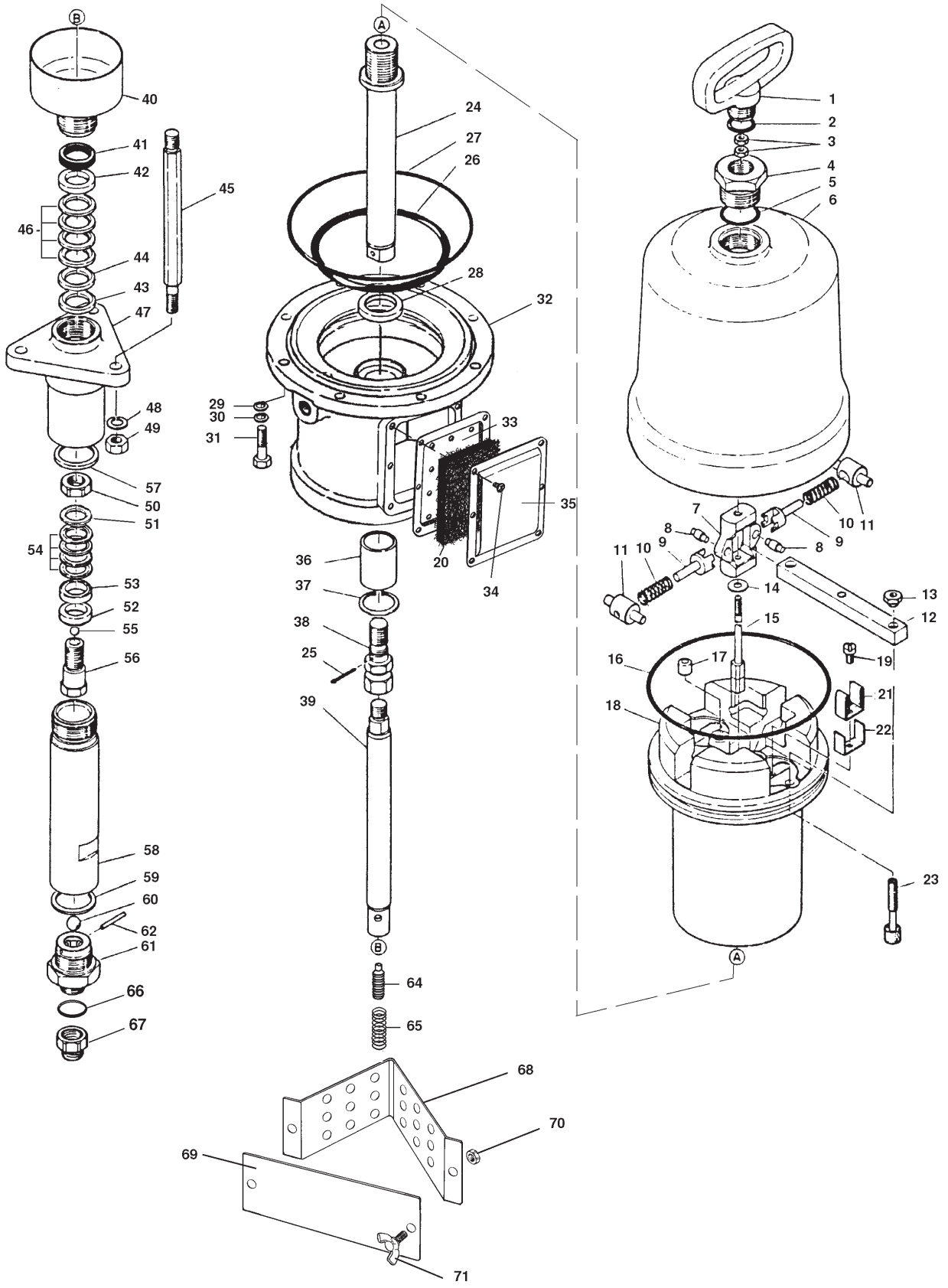



PICTURE 7

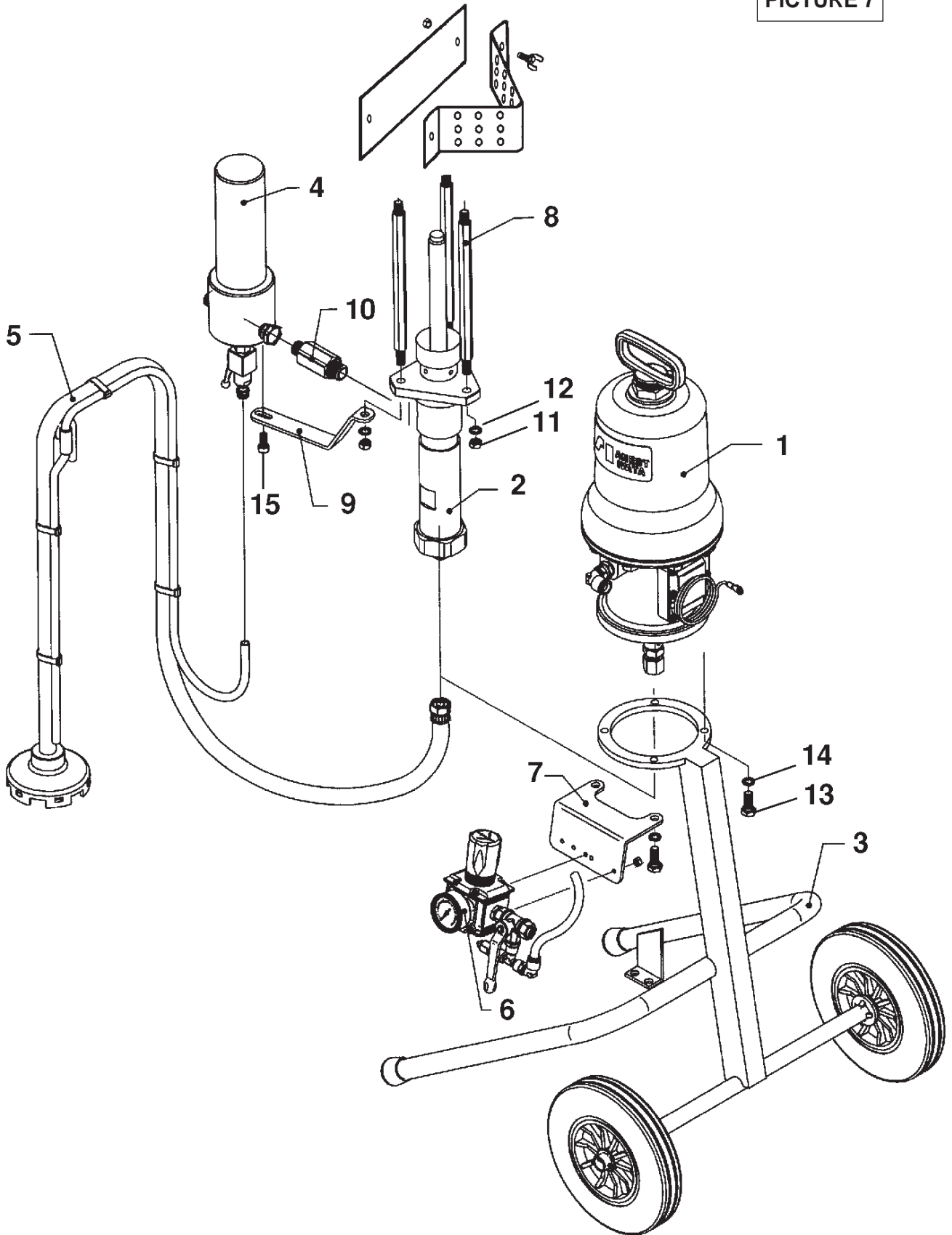



9.1

ALS 333 C

Posit.	Description
3	TROLLEY
4	TF-8 PAINT FILTER
5	1/2"- 50 MESH GALVANISED STEEL DIP TUBE
6	AIR REGULATOR GROUP (1/4")
7	REGULATOR SUPPORTING BRACKET

9.2

ALS 433 C

Posit.	Description
4	TF-8 PAINT FILTER
5	1/2"- 50 MESH GALVANISED STEEL DIP TUBE
6	AIR REGULATOR GROUP (3/8")

ALS 433 TX

Posit.	Description
4	TF 8N PAINT FILTER
5	3/4"- 30 MESH GALVANISED STEEL DIP TUBE
6	AIR REGULATOR GROUP (3/8")

9.3

ALS 453 C

Posit.	Description
4	TF 9 PAINT FILTER
5	1/2"- 50 MESH GALVANISED STEEL DIP TUBE
6	AIR REGULATOR GROUP (3/8")

9.4

ALS 423 TX

Posit.	Description
4	TF-8N PAINT FILTER
5	3/4"- 30 MESH STAINLESS STEEL DIP TUBE
6	AIR REGULATOR GROUP (3/8")

9.5

DELIVERY FILTER TF-8

For ALS 333 C - ALS 433 C

Posit. Description

Pic. A

F-1	BODY
F-2	CYLINDER
F-3	SCREW
F-4	NUT
F-5	O RING
F-6	FILTER
F-7	JOINT AP 3/8" GC_1/4" MM
F-8	DRAIN VALVE A.P. 1/4"
F-9	JOINT B.P.1/4" M8x6
F-10	JOINT RC 1/4"
F-11	JOINT AP 1/4" GC_1/4" MM
F-12	PLUG

Fig.A

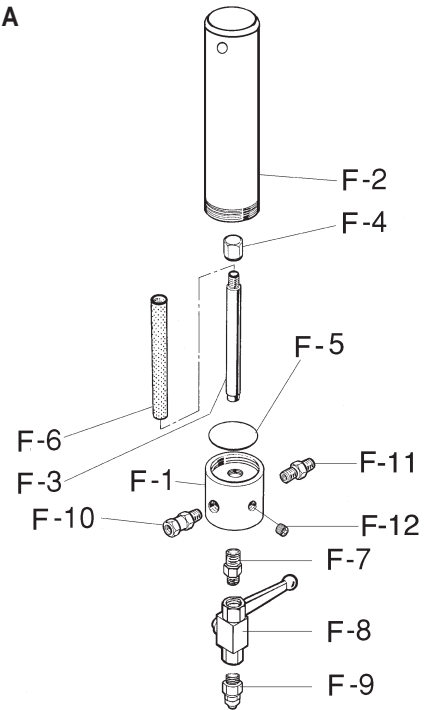

9.6

DELIVERY FILTER TF-8N

For ALS 423 TX and ALS 433 TX

Posit. Description

Pic. D

D-1	BODY
D-2	CYLINDER
D-3	SCREW
D-4	NUT
D-5	O RING
D-6	FILTER
D-7	JOINT A.P. RC 1/4" - RC 3/8"
D-8	DRAIN VALVE G 1/4" FF
D-9	JOINT B.P. 1/4" M8x6
D-10	JOINT MM 3/8"
D-11	JOINT RC 3/8"

Fig.D

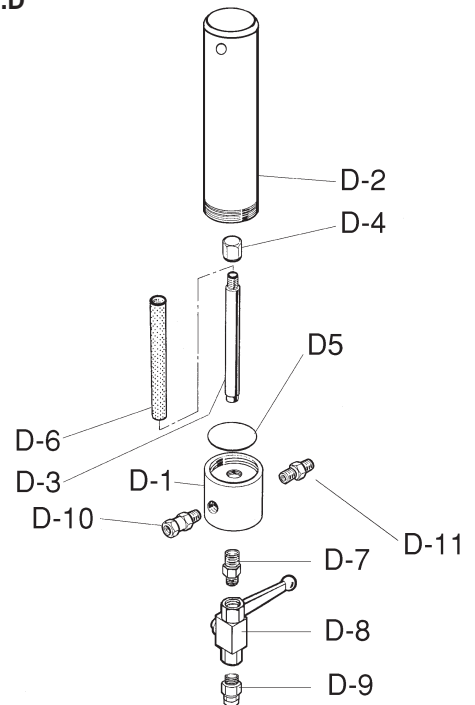



9.7

DELIVERY FILTER TF 9

ALS 453 C

Posit. Description

Fig. E

E-1	BODY
E-2	CYLINDER
E-3	SCREW
E-4	NUT
E-5	O RING
E-6	FILTER
E-7	JOINT AP 3/8" GC_1/4" MM
E-8	DRAIN VALVE A.P. 1/4"
E-9	JOINT B.P.1/4" M8x6
E-10	JOINT RC 1/4"
E-11	JOINT AP 1/4" GC_1/4" MM
E-12	PLUG

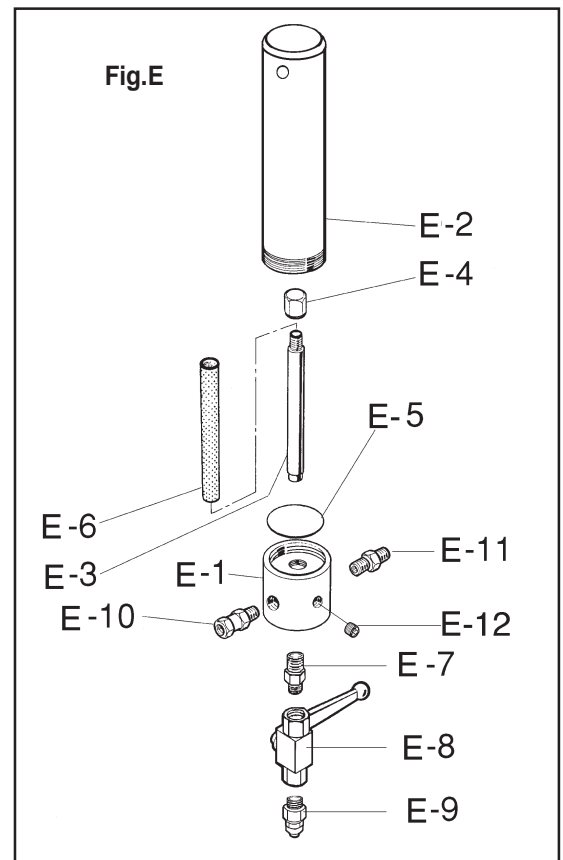

9.8 AIR REGULATION GROUP FOR ALS 333 C

Posit.	Description
3-1	GAUGE
3-2	AIR REGULATOR 1/4"
3-3	SCREW
3-4	JOINT
3-5	PLATE
3-6	HEXAGON NUT
3-7	NIPPLE R 1/4"
3-8	3 WAY VALVE 1/4"
3-10	SAFETY VALVE
3-11	T JOINT FMF
3-12	QUICK JOINT 1/4" 8x10

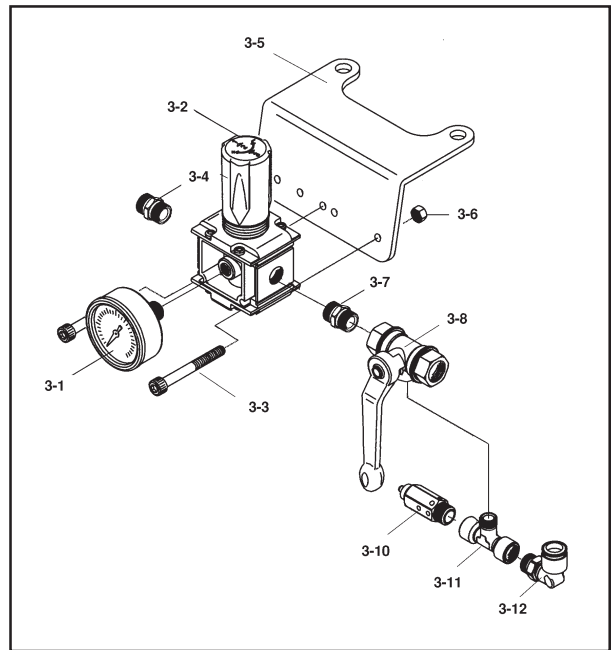

9.9 AIR REGULATION GROUP FOR ALS 433 C - ALS 433 TX ALS 423 TX - ALS 453 C

Posit.	Description
3-1	GAUGE
3-2	AIR REGULATOR 3/8"
3-3	SCREW
3-4	JOINT
3-5	PLATE
3-6	NUT
3-7	NIPPLE R 3/8"
3-8	3 WAY VALVE 3/8"
3-9	REDUCTION
3-10	SAFETY VALVE
3-11	T JOINT FMF 3/8"
3-12	QUICK JOINT 3/8" 10x2

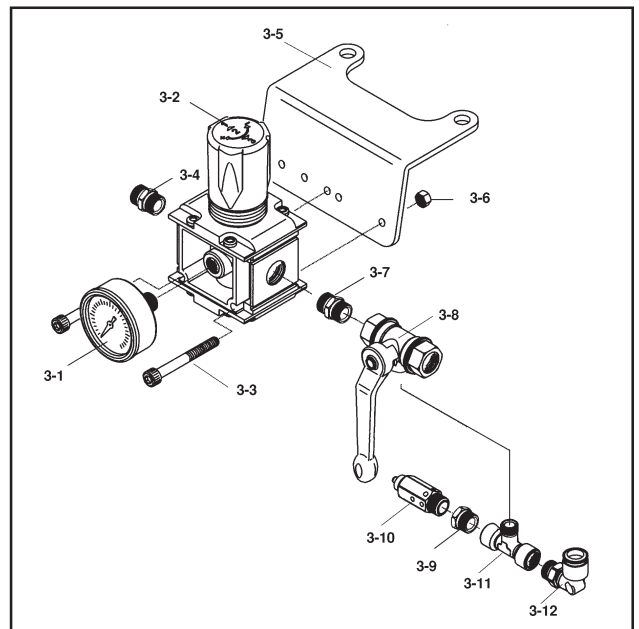



9.10 DIP TUBE GROUP WITH FILTER

Posit. Description

Pic. E THREE TYPES:

- GALVANISED STEEL DIP TUBE (1/2" with 50 MESH filter)
- STAINLESS STEEL DIP TUBE (1/2" with 50 MESH filter)
- STAINLESS STEEL DIP TUBE (3/4" with 30 MESH filter)

Posit. Description

Pic. F

1) F15X1 FILTER SET FOR DIP TUBES 1/2" (GALVANISED AND STAINLESS STEEL VERSIONS)

- 4 15x1 COMPLETE FILTER SET
- 4-1 15x1 FILTER COVER
- 4-2 50 MESH FILTER
- 4-2 100 MESH FILTER (OPTIONAL)
- 4-3 SPRING

2) G 1/2" FILTER SET FOR G 3/4" DIP TUBES

- 4 1/2" COMPLETE FILTER SET
- 4-1 1/2" FILTER COVER
- 4-2 30 MESH FILTER
- 4-3 SPRING

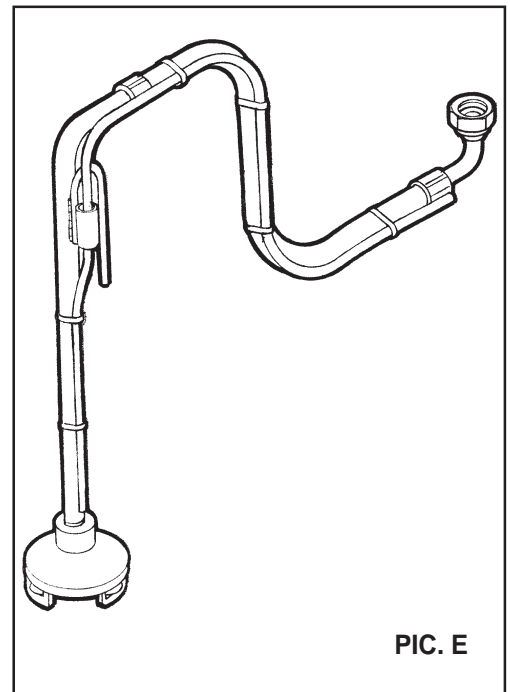

PIC. E

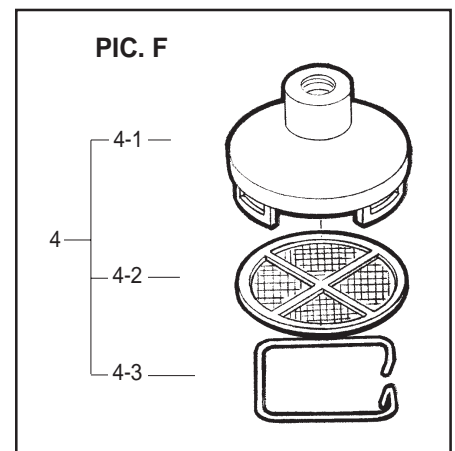

10. DISMANTLING

10.1 Equipment storage

If the airless unit is to be stored for a certain period, the following operations are recommended:

Disconnect the equipment from the energy sources.
Remove all residues and deposits from the pump.
Cover the equipment with a waterproof tarpaulin.

10.2 Dismantling

If for any reason the pump is to be dismantled, some important rules have to be followed to safe guard the environment.

All sheaths, flexible ducts and plastic or non metal components will have to be disposed of separately.





ANEST IWATA Europe S.r.l.
46, Corso Vigevano 10155, Torino Italy
Direct Tel. +39 011 - 24 80 868
Fax +39 011 - 22 74 406
info@anest-iwataeu.com
www.anest-iwataeu.com



European Sales Branches:

ANEST IWATA Italia S.r.l.

46, Corso Vigevano 10155, Torino (Italy)
Tel. diretto +39 011 - 24 80 868 - Fax +39 011 - 85 19 44
info@anest-iwataeu.com **www.anest-iwata.it**

ANEST IWATA Europe S.r.l.

SUCURSAL ESPAÑA Y PORTUGAL
Avda.del Maresme, 44-46 Planta 2 OF. 25 / 08918 - Badalona (Barcelona)
Tel.:+34 933 20 59 93 - Fax.:+34 933 20 55 64 - **info@anest-iwata.es**

ANEST IWATA Europe S.r.l.

NIEDERLASSUNG DEUTSCHLAND
Dorfäckerstr. 25, 74248 Ellhofen
Telefon: +49 (0)7134- 917368 - Fax: +49 (0)7134 - 917378
Handy: +49 (0)172 - 62 74 542
f.e.anest-iwata@t-online.de **www.anest-iwata.de**

ANEST IWATA Scandinavia AB.

Ögärdesvägen 6C, 433 30 PARTILLE
Tel. +46 (0)31 - 340 28 60 - Fax +46 (0)31 - 340 28 69
info@anest-iwata.se **www.anest-iwata.se**

ANEST IWATA France S.A.

25 rue de Madrid - BP 7405 38074 St Quentin Fallavier
Tél. +33 (0)4 - 74 94 59 69 - Fax +33 (0)4 - 74 94 34 39
info@anest-iwata.fr **www.anest-iwata.fr**

ANEST IWATA U.K. Ltd.

Unit 10 Little End Road - Eaton Socon
St. Neots - CAMBRIDGESHIRE
PE19 8JH
Tel.: +44 (0) 1480 405419 Fax: +44 (0) 1480 217610
enquiries@anest-iwata.co.uk **www.anest-iwata.co.uk**