

## AIRFED 2100

### Full Face Breathing Mask

#### IMPORTANT

Before use, adjustment or maintenance, it is important to read this instruction manual very carefully. Failure to follow these instructions completely may result in a decrease in protection or no protection at all. This manual must be stored in a safe place for any future reference that may be necessary.

Any misuse, or handling other than indicated in this Instruction manual is not covered by guarantee. CORMACK ANEST IWATA Pty Ltd disclaims all responsibility for any accident or damage caused by failure to observe the operational and safety procedures as listed in this manual. In the interest of user friendliness, this manual contains information in a brief and concise format. For any additional information you may require regarding equipment operations, if there are any missing parts or any damage during transportation is found, please contact CORMACK ANEST IWATA on 1800 672 025.

#### DESCRIPTION

The AIRFED 2100 protection mask is a compressed air fed respirator which, when supplied with breathable quality compressed air, passes it via a belt-mounted regulator and flexible tube into a visor. The regulator is fitted with a replacement nuisance odour (carbon) filter.

##### Package Contents:

- Browguard and visor assembly
- Replaceable visor cover
- Waist belt and Pre-set air regulator with carbon filter and QR fittings
- Spray gun whip hose with QR fittings, 1.2m
- Nape cover
- Storage/carry bag
- Spare part breakdown sheet
- Instruction manual
- Maintenance record sheet

#### SELECTION

The appropriate respiratory protection should be selected for the application in hand. Reference should be made to AS/NZS 1715-1994 "Selection Use and Maintenance of Respiratory Protective Devices", available from Standards Australia

***The AIRFED 2100 Full Face Breathing Mask with the air breathing hose set, complies with the Australian /New Zealand Standard 1716-1994 'Respiratory Protective Devices' and to the European Standard EN1835:1999. 'Light duty construction compressed air line breathing apparatus incorporating a helmet or hood'***

## APPLICATION

The AIRFED 2100 system is a class LDH 3 device and will provide protection against air born dusts, mists, gases and vapours up to a protection factor of 200. This means that it can be used in areas where the concentration of contaminant in the workplace air is up to 200 times the Occupational Exposure Limit (O.E.L.)

- This system should not be used where the level of contaminant exceeds 200 x the O.E.L. or where the contaminant or its level is unknown.
- This system should not be used in oxygen deficient atmospheres.
- This system should not be used below 0°C.

## OPERATION

### Air Supply Specification

- Minimum input pressure 5.5 bar. (80psi)
- Min.air consumption 160 l/min (5.6 cfm)
- Max.air consumption 300 l/min (10.6 cfm)

The above air pressures and consumption are for the airfed mask only. When using a spray gun on the whip hose, the air supply should be adjusted higher to accommodate both the mask and the spray gun.

**NOTE: The air supply must be of breathable quality as defined in AS/NZS1715-1994, "Selection, Use and Maintenance of Respiratory Protective Devices".**

### Air Supply Hose Specification

The AIRFED 2100 system should be used with a single 10mm ID air breathing hose to **AS/NZ 1716/2299** with maximum working pressure of 2.5MPa and maximum length of 10 mtr. The air breath hose is only suitable for use in areas where risk of damage is low and movements of the wearer are limited. It has no additional antistatic or heat resistant properties.

### Visor Air Supply Specification And Air Flow Indicator

Minimum Design Flow rate: 160 l/min.

An air -flow indicator (AFI) is positioned in the visor on the left-hand edge of the wearer's field of vision. When the flow of air drops below the minimum design flow rate, the float will just break the upper edge of the opaque portion of the tube (refer to fig. 1). If a drop in airflow is indicated in this way, perform the checks listed below under "Air flow indicator troubleshooting".

### Regulator Specification

This regulator has limited adjustment. Do not attempt to over adjust the regulator. The regulator will not shut off completely. The adjustment allows the user to maintain sufficient airflow to the visor when using auxiliary attachments and to adjust for comfort.

## BEFORE USE

**The following should be performed in an uncontaminated area.**

- Check that the air supply pressure and flow available are in accordance with the above air supply specification.
- Inspect the equipment before use for any signs of damage or deterioration. Do not use the equipment if it appears to be damaged.
- Fit the belt with the regulator attached around the operator's waist with the regulator on the side of the body. Lock the buckle and adjust the belt to a comfortable tightness.
- Connect the loose female nut end of the air breathing supply hose to the main air supply (the outlet of the filter/regulator/coalescer). Connect the female end of the air breathing supply hose to the male inlet of the waist belt regulator. (See Figure 2)

**NOTE: When assembling the air breathing hose to the waist belt regulator, ensure that the lockable coupling used is placed into the locked position by turning ¼ turn, in either direction. Test to see that the coupling cannot accidentally open. To uncouple: align the locking lugs and retract the sleeve**

- Remove the protective film from the outside and inside of the visor screen (hood assembly). Fit the enclosed visor cover by pushing it over the two metal studs.
- Connect the visor air tube to the outlet of the regulator (on the waist belt) ensuring that it is locked in place. This is a double action connector /coupling which requires two distinct actions to disconnect. (see diagram)

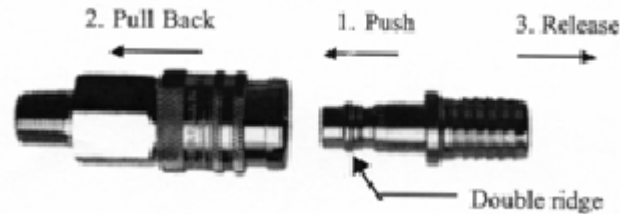

- Check the air quality from the visor. If any odour is detectable the cause should then be investigated since further pre-filtering will probably be required.
- If an accessory such as spray gun or power tool is to be driven from the same compressed air supply tube, ensure that the airflow indicator shows sufficient air flow is being delivered into the visor when the accessory is consuming the maximum airflow requirement.

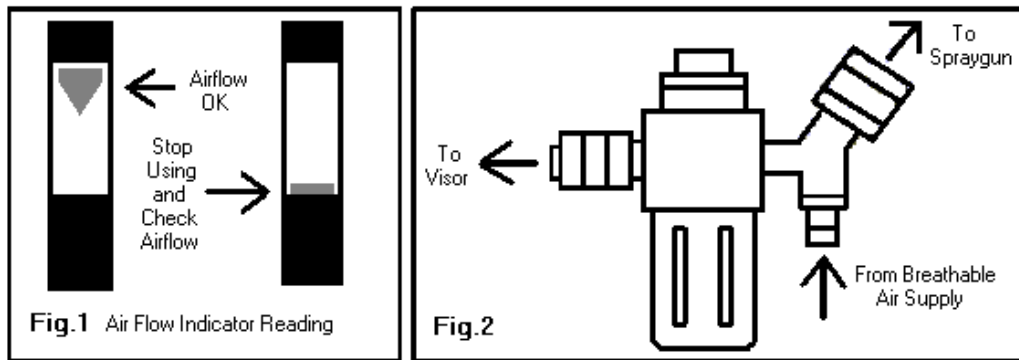

## FITTING THE VISOR ASSEMBLY

- Open out the head harness by pressing and rotating the knob on the back of the harness.
- To fit the head harness, adjust the crown strap and the knob at the back of the head harness until the face seal fits around the face when the visor is flipped down.
- The light duty breathing hose should run down the back of the user.

## IN USE

- If an oil odour develops during use check the quality of the air supply from all upstream in-line filtration, replace filter cartridges if dirty. If all is OK check the carbon filter on the waist belt, it may need replacing. All filters should be checked to ensure that the air being fed to the breathing equipment is free from oil mist.

## CARE AND MAINTENANCE

**All maintenance should be performed in an uncontaminated area.**

- Visor covers (AF2102K10) should be replaced when contamination starts to obscure vision. Replace by pulling off and pushing a new visor cover over the two metal studs.
- The complete kit of equipment should be inspected on a monthly basis (or before use for occasional users) and any worn or damaged components be replaced. Particular attention should be paid to the visor and its face seal.
- Inspection of the carbon filter inside the regulator should occur on a regular basis. Replace the filter if an odour is detected, if discoloration has occurred, if the airflow is restricted and/or if water is detected.
- The equipment has an estimated shelf life of 5 years from the date of manufacture.
- The equipment should be stored in an uncontaminated environment away from direct sunlight preferably packed in an enclosure. Recommended limits of storage are –10 to 50°C with RH < 60%.

## AIR FLOW INDICATOR (AFI) TROUBLESHOOTING

**If the AFI indicates a drop in airflow (refer to fig.1), perform the following check under uncontaminated conditions:**

- Ensure that the compressed air supply is turned on at the wall and that the input pressure is correctly adjusted.
- Check the security of the rigid airflow indicator tube positioned in the visor. If it has come loose from the end of the flexible transparent hose, push it back into place.
- Make sure that the transparent breathing hose is not kinked, blocked or holed.
- If there is a failure or suspected failure of the regulator, it should be returned freight prepaid to Cormack Anest Iwata Pty Ltd for testing, rectification or replacement.

## CLEANING

- The external surfaces of all components may be cleaned using a sponge and warm soapy water and afterwards rinsed, then allowed to dry naturally.
- Do not immerse any part of the system in water, particularly the regulator system.

## WARNINGS

- If the face seal does not fit closely to the face then the stated levels of protection may not be achieved.
- This airfed system should not be used below 0°C.
- This air fed system should not be used in or with oxygen or oxygen enriched air.
- At very high work rates the pressure in the visor may become negative at peak inhalation flow.
- The protection factor may not be achieved with persons with excessive facial hair or glasses.
- The user must ensure the purity and identity of the breathing air supply at all times.
- In certain highly toxic atmospheres this airfed mask may not provide adequate protection.
- This airfed mask should not be used in area where inhalation of the atmosphere, whilst escaping in the event of failure of the air supply, would cause serious harm to health.
- The air supply system should be equipped with an appropriately rated and adjusted pressure relief safety valve.
- The visor offers impact protection to EN166-F and optical class 1. These levels may be lowered if correct care is not taken of the equipment. Optical clarity may be affected by contamination or by one or more visor covers.

## REPLACEMENT OF VISOR AND CHINGUARD

### REMOVING THE VISOR/CHINGUARD

1. Remove the face seal from mask.
2. Loosen the tension control knobs on the sides of the brow guard.
3. Unclip the 2 clips that hold the Air Flow Indicator onto the face screen.
4. Press the button "B" on the side of the brow guard until it releases the corner of the screen, allowing it to be pulled free.
5. Repeat for the other side.
6. Free the visor from the central tooth and remove from the brow guard.

### FITTING THE VISOR/CHINGUARD TO THE BROWGUARD

1. Guide the U-slotted spade ends of the chin guard into the slot at the rear of the brow guard.
1. Feed the square hole in the back corner of the chin guard into the slot between the brow guard and boss mouldings, aligning the square hole with the hole "A" in Fig. 3. Push down until it clicks home.
2. Repeat for the other side.
3. Feed the top edge of the screen into the channel around the front of the brow guard, pushing down over the central angled tooth until it locks.
4. Push the 2 clips that hold the Airflow Indicator into the 2 holes in the visor screen.
5. Adjust the tension control knob on the side of the brow guard so the visor can move to your requirements.
6. Replace face seal.

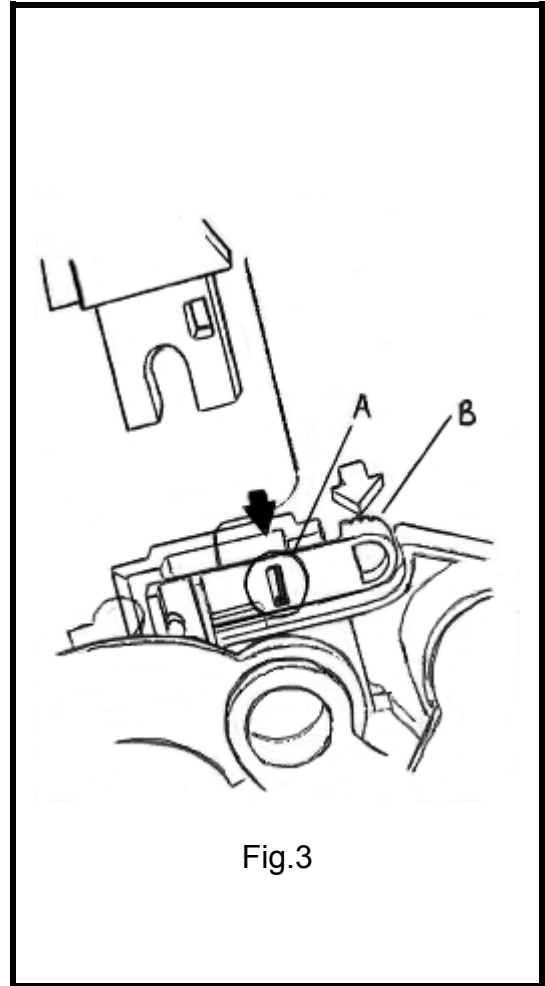

## SPARE PARTS & ACCESSORIES

### AF2100 Mask/Hood Set

- AF2003 Adjustable Waist Belt
- AF2006 Carbon Filter
- AF2101 Hygiene Kit (face and brow seal)
- AF2102K10 Visor covers Pkt 10
- AF2103 Nape Cover
- AF2104 Chin guard and Visor
- AF2105 Head & Visor Assembly
- AF2106 Diffuser Assembly
- AF2107 Adjustable Filter Regulator
- 200.20SM QR Coupling 1/4 male
- 20PM QR Adapter 1/4 male

### AFGH12 Spray Gun Hose 1.2mtr w/QR Fitting

- 200.20SH QR Coupling 3/8 hose barb
- 20PFF QR Adapter 1/4 female
- 30PH QR Adapter 3/8 hose barb
- B00 Air Hose per mtr

### AFBH10 Air Breathing Hose 10mtr w/QR Fittings

- L20SH Lockable QR Coupling 3/8 barb
- 6TN4 1/4 Nut & 3/8 Tail
- 33.10 Air Breath Hose per mtr

Manufactured in the UK.

Distributed by

**CORMACK**



**ANEST IWATA**

## Cormack Anest Iwata Pty Ltd

ACN 079 933 967 ABN 12 079 933 967  
Unit 3, 10 Boden Road, Seven Hills NSW 2147  
PO Box 6623, Blacktown Business Centre  
BLACKTOWN NSW 2148 AUSTRALIA

**Telephone: 61 (02) 9853 2000**

**Fax: 61 (02) 9853 2090**

**Email: info@anest-iwata.com.au**

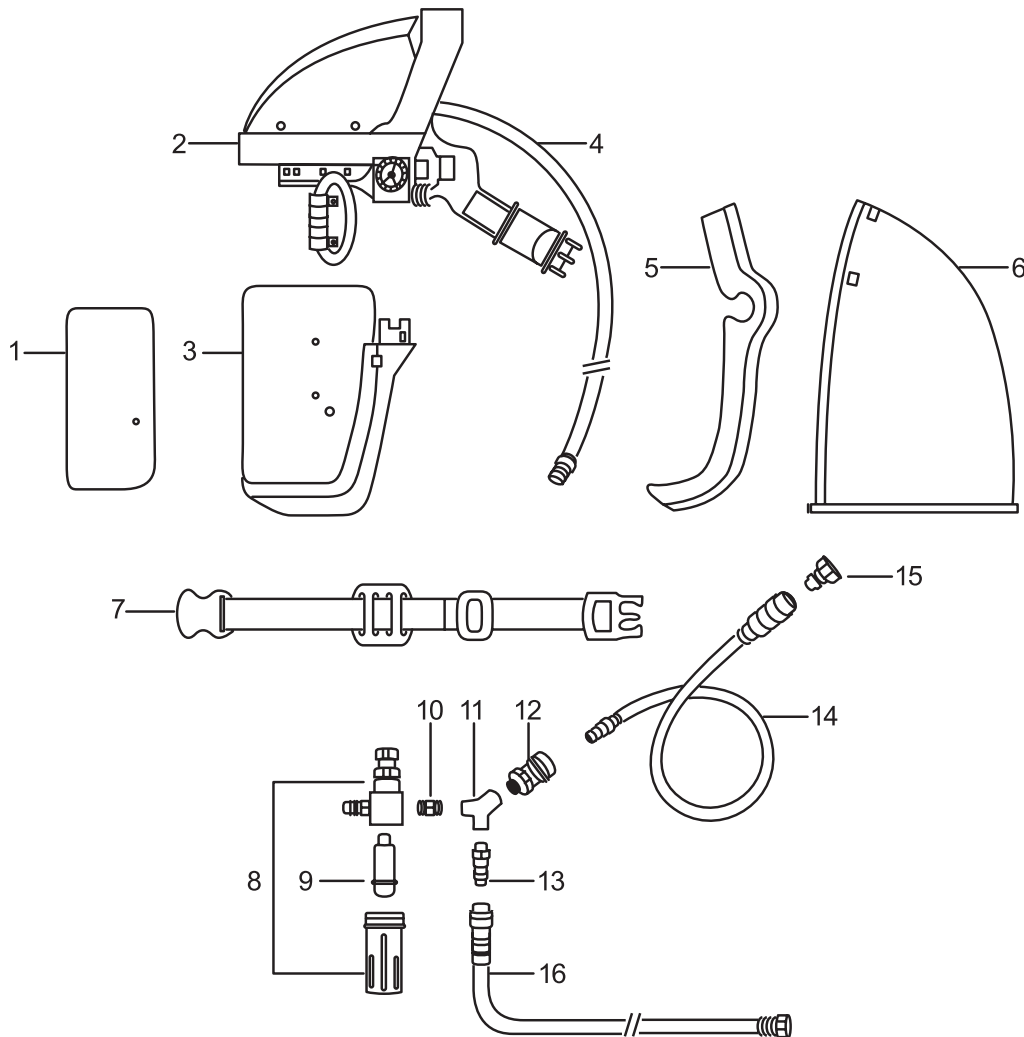

Item No.	Part No.	Description
1	AF2102K10	Visor Covers Pkt 10
2,3,4,5	AF2105	Head/Visor Assembly (w/o nape cover & visor cover)
3	AF2104	Chinguard & Visor
4	AF2106	Diffuser & Hose Assembly
5	AF2101	Hygiene Kit - Fabric Face Seal & Foam Brow Seal
6	AF2103	Nape/Head Cover
7	AF2003	Adjustable Waist Belt
7-13	AF2107C	Waist Belt, Filter Regulator and Fittings Assembly
8,9	AF2107	Carbon Filter Regulator
9	AF2006	Replacement Carbon Filter
10	441	Nipple 1/4 M
11	498	Y Piece 1/4 F
12	200.20SM	QR Coupling 1/4 M
13	20PM	QR Adapter 1/4 M
14, 15	AFGH12	Spraygun Hose Set 1.2m with QR Fittings
option	GH12	Flexible Spraygun Hose Set 1.2m with QR Fittings
15	20PFF	QR Adapter 1/4F
16	AFBH10	Air Breathing Hose Set 10m with QR Lock Coupling & Nut/Tail Fitting
option	BH10	Air Breathing Hose Set 10m without Coupling & Nut/Tail Fitting



## **REPORT**

**No:** 21799  
**Date of Issue:** 7 September 2001  
**File No:** 2001/012299 0001

**Prepared for:**

**CORMACK ANEST IWATA PTY LTD**

### **AIRFED MASK AIRLINE RESPIRATOR WITH SPRAY GUN**

The respirators as listed in equipment, satisfied the performance requirements of the Standard.

The W-400 Spray Gun has the highest usage rate of the series (12 Cfm). Therefore, any spray gun capable of drawing up to the above flowrate at the pressure indicated may be used with the airline respirators. The instructions show the use of the Air Flow Indicator (AFI). The AFI indicates airflow is satisfactory when the float is at the top of the float chamber.